



ZHEJIANG YILIDA VENTILATOR CO.,LTD.

SYP

系列离心式空调风机

Centrifugal Ventilators

冷凝水盘

Condensate Plates

2006

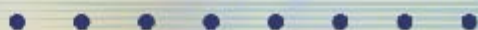

浙江亿利达风机有限公司
ZHEJIANG YILIDA VENTILATOR CO.,LTD.



COMPANY PROFILE 企业简介

浙江亿利达风机有限公司是国内规模最大的空调风机生产企业之一，国家级高新技术企业，美国AMCA协会会员单位。公司占地面积86000m²，技术力量雄厚，拥有先进的生产、检测设备，按照美国AMCA标准要求建立了风机综合性能测试室，亿利达风机高新技术研究开发中心通过了省级认定，在国内空调风机行业率先通过ISO9000质量管理体系、ISO14001环境管理体系认证。

多年来公司与科研单位紧密合作，开发生产拥有自主知识产权的SYP、SYB、SYD、SYT、SYZ、SYH、SYQ等系列空调风机，经国家机械工业通用机械产品检测所检测和广大顾客使用验证，性能达到国内领先水平，是中国制冷空调工业协会、中国制冷学会推荐(主导)产品，浙江省名牌产品，SYD、SYH、SYQ系列风机通过美国AMCA产品认证，风机产品列入国家重点新产品、国家级火炬计划项目，“YILIDA”商标被评为浙江省著名商标。产品为约克、特灵、麦克维尔、顿汉布什、新晃、格力、美的、日立、LG电子、长虹、冰山、天加、康达、艾默生、清华同方、国祥、盾安、台佳等100多家中央空调生产企业配套，并出口欧美、东南亚、中东等地。目前盘管风机国内市场占有率约为55%，冷凝水盘国内市场占有率约为45%。

公司与全球领先的风机和通风设备制造商德国WOLTER(华德)公司合资，“WOLTER”一流的设计研发能力和“YILIDA”强大的制造能力以及完善的营销服务网络相结合，共同为顾客提供最佳性价比的空调风机及工程风机系列产品和服务，愿与海内外同仁携手共创空调暖通行业美好的明天。

Zhejiang Yilida Ventilator Co., Ltd. is one of the largest air-conditioning (A/C) ventilator manufacturers in China. The company is a State-recognized high-tech enterprise and is a member of AMCA International. It has a total plant area of 86,000 square meters and employs a highly trained engineering and production staff. It possesses state-of-the-art manufacturing and testing equipment. Its engineering lab is capable of testing all size of its products per AMCA standard in air and sound. It is the first company in China A/C ventilator industry to receive ISO9000 quality system and ISO14001 environment system certificates.

The SYP, SYB, SYD, SYT, SYZ, SYH and SYQ series of A/C ventilators and drain pan were developed in close cooperation with a number of leading research institutes in China. Some of these products were tested by China Mechanical Industry General Machinery Product Inspection Institute and validate by most customer use to have superior performance characteristic and were recommended by China Refrigeration and Air Conditioning Industrial Association, and by Chinese Refrigeration Association. Two types of fans are recognized as national key new products; one type of fans is listed into Nation Torch project. SYD and SYH and SYQ Series fans are licensed to bear the AMCA Seal. "Yilida" is recognized as Zhejiang province famous trademark. The products are currently being supplied to more than one hundred A/C equipment manufacturers in China, noticeably York, Trane, Mcquay, Dunham-Bush, Sinko, Gree, Midea, Hitachi, LG electronic, Changhong, Bing Shan, Tica, Tong Fang, Kingair, Dunan, Kangda, Emerson and Tecka. They are also being supplied to customers in Europe, America, Middle East and Southeast Asia countries. Yilida SYP series fans now have more than 55% market share and its drain pans have more than 45% market share in China.

A newly founded joint venture company invested by Yilida and Wolter, one of the leading ventilator manufacture company in Germany, will provide our clients more and more highly efficient and most reliable products with very competitive price. We will stands ready to cooperate with new and old customers alike, at home and abroad, in order to promote the global A/C industry.

企业使命：

致力风机产业发展 开发节能环保产品
树立行业精品典范 打造国际知名品牌



广东新厂房 Guangdong new factory



总部新厂房 Headquarters new factory





质量方针:

诚 信 为 本
顾 客 至 上
科 技 先 导
品 质 卓 越



概述 Outline

1

SYP系列离心式空调风机是本公司在国内首家推出的中央空调风机盘管专用前向多翼离心式金属风机，产品采用进口优质热镀锌钢板及冲压成型工艺，具有效率高、噪音低、能耗少、结构精巧等特点，流量和压力能满足宽广的运行范围，叶轮直径130-250mm，风量250m³/h-3000m³/h。产品达到国内领先水平，首家替代进口，目前国内市场占有率55%以上。

SYP Series Air-conditioning Ventilator, used for fan coil only, is the forward multi-vane centrifugal metallic ventilator developed and manufactured first by our company in the country. The ventilator impellers are made of high quality of hot galvanizing steel sheet by using stamping technology with the advantages of high efficiency, lower noise and precision construction. Both the flow volume and pressure can meet with wide application, and the diameter of the impeller is from 130mm to 250mm. The flow volume ranges from 250m³/h to 3000m³/h. Our products have reached the advanced level and have replaced those imported ones first in the country. Now the products have 55% share of the domestic market.



产品命名方式 Designation of Products

2

SYP系列风机命名方式由风机系列代号、叶轮名义直径、叶轮名义长度、工艺特性组成：

The model designations signify code of series ventilator, the nominal diameter of impeller, nominal length of impeller, technological characteristics:

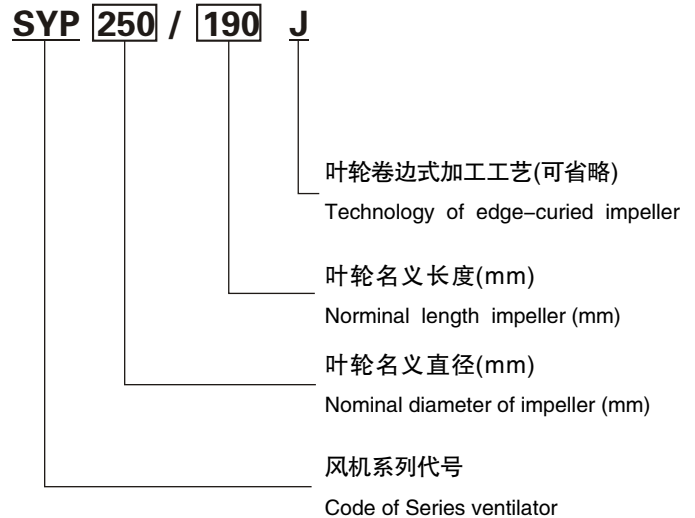

产品型式 Type of Product

3

风机按轴套安装的方向可分为右式和左式，从轴套一端正视，叶轮顺时针旋转的称为右式、逆时针旋转的称为左式。

According to the installed position of the hub, the ventilator can be divided into two types, right type and left type; viewing from hub side, if the impeller rotates clockwise, the ventilator is called right type; if it rotates anti-clockwise, the ventilator is called left type.

产品结构 Contruction of Product

4

SYP系列风机主要由机壳、叶轮、轴套构成。

1. 机壳

机壳选用进口优质热镀锌钢板制造，侧板具有符合空气动力的外形，蜗板以咬边的方式，用自攻螺钉与侧板连接成一体。在出风口，蜗板设计成符合空气动力的特殊风舌，以阻止在出口气流中形成漩涡。

2. 叶轮

叶轮选用进口优质热镀锌钢板经精密级进模冲压、卷边成型，合理的设计使风机的气动性能达到最佳状态。

3. 轴套

叶轮与电机轴由轴套连接，轴套采用结构钢加工而成或锌合金经压铸后精加工而成，轴孔的公差、垂直度、同轴度允差均在0.01之内。

SYP Series ventilator consists of mainly housing impeller and hub.

1. Housing

The housing is made of imported quality hot-galvanizing steel sheet. The side plates take the shape according to the aerodynamic profile and are fixed with biting-scroll with tapping screws. In the air outlet, the plate of scroll is designed to a special snail configuration according to aerodynamics to prevent from forming burble in the air stream of outlet.

2. Impeller

The impeller is made of high-grade imported hot-galvanizing steel sheet punched with precision mould and curled. The reasonable design of impeller makes the ventilator work in the optimum condition.

3. Hub

The connection of impeller with electric motor shaft is guaranteed by the hub which is made of constructional steel or die cast zinc alloy followed by precision processing. The permissible tolerance of hole diameter, perpendicularity and coaxality are all kept within 0.01mm.

风机性能 Performance of Ventilator

5

1. 本样本中风机性能均指在标准状态下的性能。即风机进气状态为：

进气压力 $Pa = 101.325KPa$

进气温度 $t = 20\text{ }^{\circ}C$

进气气体密度 $\rho = 1.2Kg/m^3$

若用户实际使用的气体进气状态或使用的风机转速改变时则可按下列关系式换算：

$$\frac{Q_0^*}{Q_0} = \frac{n^*}{n}$$

$$\frac{P_0^*}{P_0} = \frac{n^{*2}}{n^2} \cdot \frac{\rho^*}{\rho} \quad \frac{P_0^*}{P_0} = \frac{n^{*2}}{n^2} \cdot \frac{Pa^*}{Pa} \cdot \frac{273+t}{273+t^*}$$

$$\frac{Nin_0^*}{Nin_0} = \frac{n^{*3}}{n^3} \cdot \frac{\rho^*}{\rho} \quad \frac{Nin_0^*}{Nin_0} = \frac{n^{*3}}{n^3} \cdot \frac{Pa^*}{Pa} \cdot \frac{273+t}{273+t^*}$$

上述式中

(1) 流量 $Q_0(m^3/h)$ 、压力 $P_0(Pa)$ 、转速 $n(r/min)$ 、内功率 $Nin_0(Kw)$ 由性能曲线上查得。

(2) 右上角加符号“*”的则为用户实际使用气体进气状态下所需的性能参数。

1. The ventilator performance in this catalogue denotes the performance in standard conditions. It denotes air inlet conditions of ventilator as follows:

Air inlet pressure $Pa = 101.325KPa$

Air temperature $t = 20\text{ }^{\circ}C$

Inlet gas density $\rho = 1.2Kg/m^3$

If the practical air inlet conditions or the speed of the operating ventilator changes, the conversion can be carried out according to the following expression:

$$\frac{Q_0^*}{Q_0} = \frac{n^*}{n}$$

$$\frac{P_0^*}{P_0} = \frac{n^{*2}}{n^2} \cdot \frac{\rho^*}{\rho} \quad \frac{P_0^*}{P_0} = \frac{n^{*2}}{n^2} \cdot \frac{Pa^*}{Pa} \cdot \frac{273+t}{273+t^*}$$

$$\frac{Nin_0^*}{Nin_0} = \frac{n^{*3}}{n^3} \cdot \frac{\rho^*}{\rho} \quad \frac{Nin_0^*}{Nin_0} = \frac{n^{*3}}{n^3} \cdot \frac{Pa^*}{Pa} \cdot \frac{273+t}{273+t^*}$$

where:

(1). Volume $Q_0(m^3/h)$, pressure $P_0(Pa)$, speed $n(r/min)$, and $Nin_0(Kw)$ can be obtained from Performance chart.

(2). Asterisk (*) on the upper right corner denotes the performance parameter needed by the customers in practical gas inlet conditions.

(3). The difference in relative humidity is omitted from the above-mentioned formulas.

2. 性能曲线图上的功率 N_{in0} 是指风机的内功率。
 (1) 风机轴功率: $N_s = N_{in0}$
 式中: N_s —风机轴功率

(2) 配套电机的功率: $N = N_s \cdot K$
 式中: N —配套电机的功率
 K —电机容量安全系数
 电机容量安全系数的取值方法可参照表1。

2. The power (N_{in0}) on the performance chart the internal power of the ventilator.

(1) Shaft power of ventilator: $N_s = N_{in0}$
 where: N_s —Shaft power of ventilator

(2) Power of matching electric motor: $N = N_s \cdot K$
 where: N —Power of matching electric motor
 K —Safety coefficient of electric motor capacity
 The value of safety coefficient of electric motor capacity can be obtained from Table 1.

电动机功率power of electric motor(Kw)	K值value k
< 0.5	1.5
0.5-1	1.4
>1-2	1.3

表1 (Table 1)

3. 本样本中风机噪声值是按国标规定在离进风口1m处测定的声压级指标。

3. The sound pressure in this catalogue is measured in one meter away from the ventilator inlet according to the china standard.

说明 Instructions

6

1. 风机在运输、装卸过程中应小心轻放, 防止碰撞挤压, 不得存放于潮湿、有腐蚀性物品的场合。
2. 风机安装前应对机壳内部进行检查, 壳体内部不应有遗留的工具和杂物。
3. 风机安装后用手拨动叶轮, 检查是否有过紧或碰撞现象, 确认没有这些现象时方可进行试转。
4. 风机正式运转前, 需检查电机的转向是否符合风机转向的要求。
5. 订货时须注明风机型号规格、左式或右式、轴套孔径等有关要求。

1. During transportation, load and unload, it is strictly prohibited to shock the ventilators or put them in wet and corrosive place.
2. Prior to installation, the ventilator should be subject to inspection. Inside the casing there should not be tools or something remained.
3. Following the installation, the impeller should be turned by hand to make sure that it turns freely. Once this is verified, the ventilator can be operated normally.
4. Prior to official operation of ventilator, it is necessary to check the rotating directions of both motor and ventilator for their coordination.
5. During ordering it is necessary to state the type of ventilator, right type or left type and diameter of shaft hole .

SYP130/190J

推荐使用范围的性能参数

Performance Parameter of Recommended Using Region

转速 Speed r/min	序号 Series No.	风量 Volume m ³ /h	全压 Total Pressure Pa	静压 Static pressure Pa	内功率 Inner Power W	声压级 Sound Pressure Level dB(A)
700	1	110	28	26	2	28
	2	156	28	25	2.5	29
	3	195	28	23	3	29
	4	243	27	19	3.1	31
	5	278	23	13	3.5	33
800	1	126	36	34	3	31
	2	179	37	33	3.5	32
	3	222	36	30	4	33
	4	277	35	25	4.5	34
	5	318	30	17	5	36
900	1	142	46	43	4.5	35
	2	201	44	38	5	35
	3	250	46	38	6	36
	4	312	44	31	6.5	37
	5	357	39	22	7	39
1000	1	158	57	53	6	37
	2	223	58	51	7	38
	3	278	56	46	8	39
	4	347	54	39	9	40
	5	397	48	27	10	42
1100	1	173	68	64	8.5	40
	2	245	70	62	9	40
	3	306	68	56	10.5	41
	4	381	66	47	11.5	43
	5	437	58	33	13	45
1200	1	189	81	77	11	42
	2	268	83	74	12	43
	3	333	81	67	13.5	43
	4	416	78	56	15	45
	5	476	69	39	17	47
1300	1	205	96	90	14	44
	2	290	97	86	15	45
	3	361	95	78	17	46
	4	450	92	65	19	47
	5	516	80	46	21	49

外型及安装尺寸 Overall Size and Erection Size

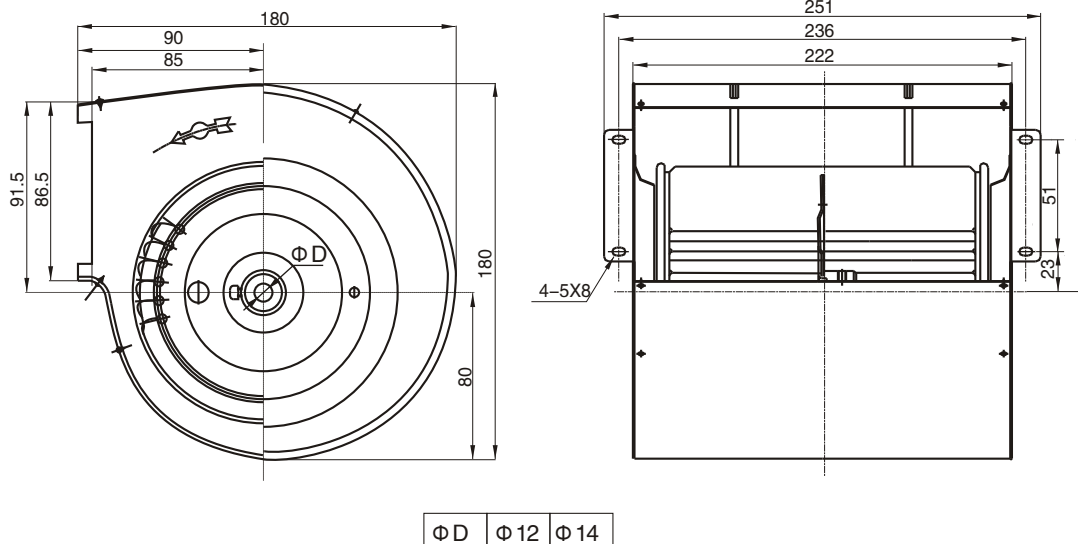

ΦD $\Phi 12$ $\Phi 14$

SYP130/190J

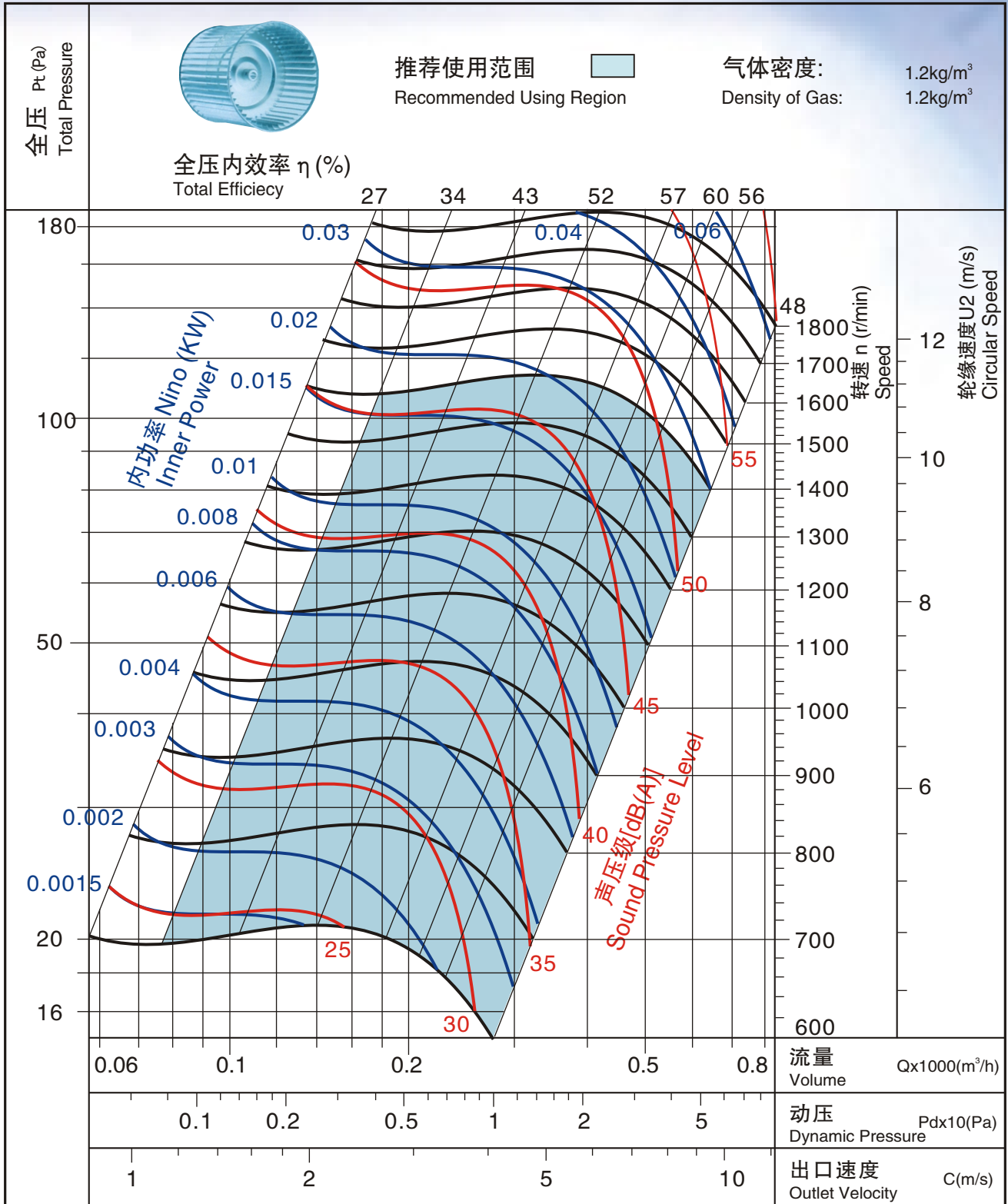

SYP145/130J

推荐使用范围的性能参数

Performance Parameter of Recommended Using Region

转速 Speed r/min	序号 Series No.	风量 Volume m³/h	全压 Total Pressure Pa	静压 Static pressure Pa	内功率 Inner Power W	声压级 Sound Pressure Level
700	1	170	38	33	3	31.5
	2	235	39	30	4	33
	3	270	38	26	4	34.5
	4	290	38	24	4.5	35.5
	5	325	36	19	5	37
800	1	180	50	43	4	35
	2	265	51	39	5.5	37
	3	305	50	34	6.5	38.5
	4	330	50	32	7	40
	5	370	47	25	8	40.5
900	1	220	63	54	6	39
	2	300	64	49	8	41
	3	345	63	43	9	42.5
	4	370	63	40	9.5	43
	5	415	60	32	11	44
1000	1	245	78	67	8	41.5
	2	335	79	60	11	43.5
	3	385	78	53	12.5	44.5
	4	410	78	49	13	46
	5	460	74	39	15	47
1100	1	270	94	81	11	44.5
	2	370	96	73	14.5	46.5
	3	420	94	64	16.5	48
	4	450	94	60	17.5	48.5
	5	510	90	48	20	50
1200	1	295	112	96	14	47
	2	400	114	87	19	49
	3	460	112	76	21.5	50
	4	495	112	71	22.5	51
	5	555	107	57	26	52.5
1300	1	320	131	113	19	49
	2	435	133	102	24	51
	3	500	131	90	27	52.5
	4	535	131	83	28.5	53
	5	500	125	67	33	54

外型及安装尺寸 Overall Size and Erection Size

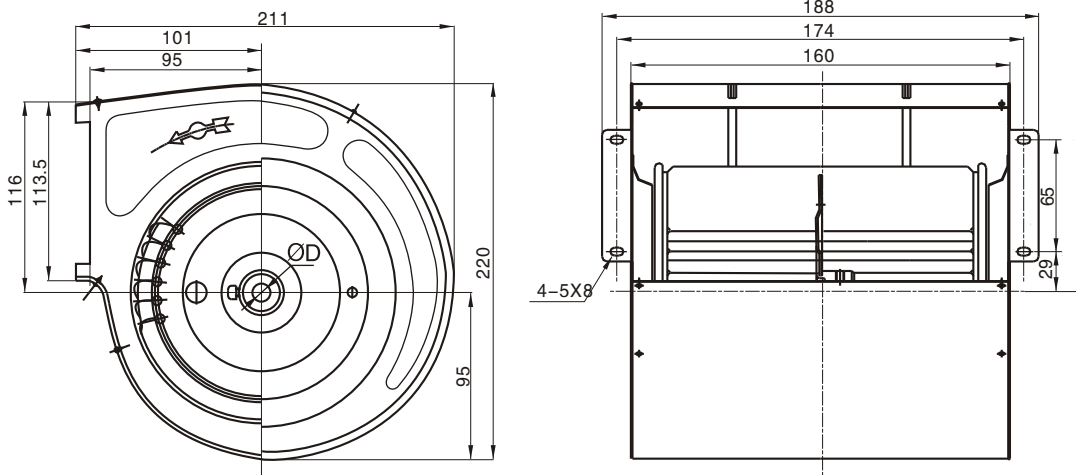

ΦD Φ12 Φ14

SYP145/130J

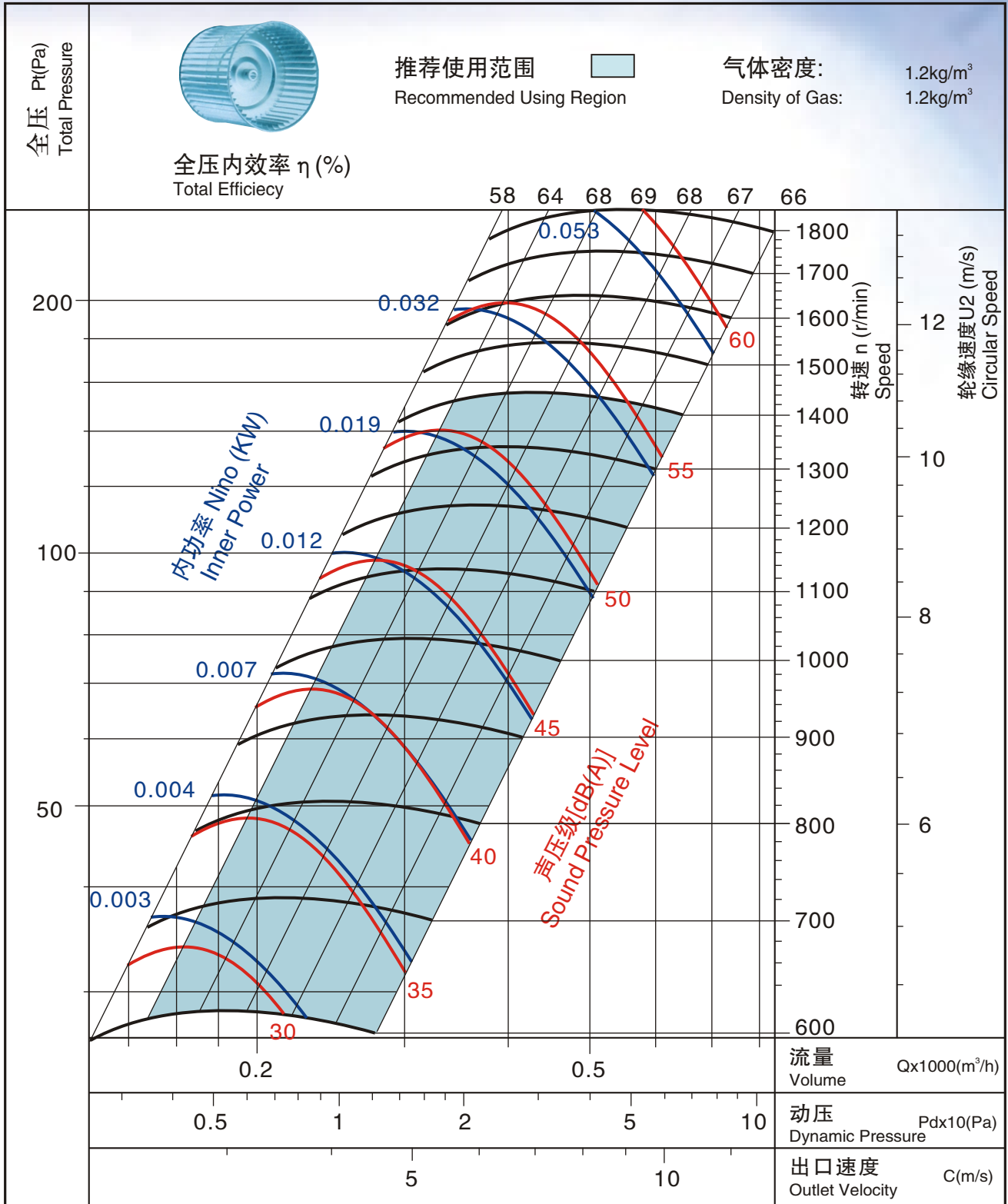

SYP145/160J

推荐使用范围的性能参数

Performance Parameter of Recommended Using Region

转速 Speed	序号 Series	风量 Volume	全压 Total Pressure	静压 Static pressure	内功率 Inner Power	声压级 Sound Pressure Level
r/min	No.	m³/h	Pa	Pa	W	
700	1	190	38	34	4	32
	2	270	40	32	5.5	33
	3	325	39	28	6.5	34
	4	355	38	25	7	35
	5	395	33	16	8.5	36
800	1	220	50	44	7	36
	2	310	52	42	8.5	37
	3	370	51	36	9	37.5
	4	405	50	32	10	39
	5	450	43	21	11.5	40
900	1	245	63	56	9	39
	2	350	66	53	11.5	40
	3	415	65	46	14	41.5
	4	455	63	41	15.5	42.5
	5	510	55	27	17.5	44
1000	1	275	78	69	12	42.5
	2	390	82	65	15.5	43
	3	460	80	57	19	44
	4	505	78	51	21	45.5
	5	565	68	33	24	46
1100	1	300	94	84	16	45
	2	430	99	79	21	46.5
	3	510	97	69	25.5	47.5
	4	555	94	61	28	48
	5	620	82	40	32	50
1200	1	330	112	100	20.5	47.5
	2	465	117	94	27	48
	3	555	116	82	33	49
	4	610	112	73	36.5	50.5
	5	680	98	48	42	51.5
1300	1	355	131	117	26	50
	2	505	138	111	34.5	50.5
	3	600	136	96	41.5	52
	4	660	131	86	46	53
	5	735	115	56	53	54

外型及安装尺寸 Overall Size and Erection Size

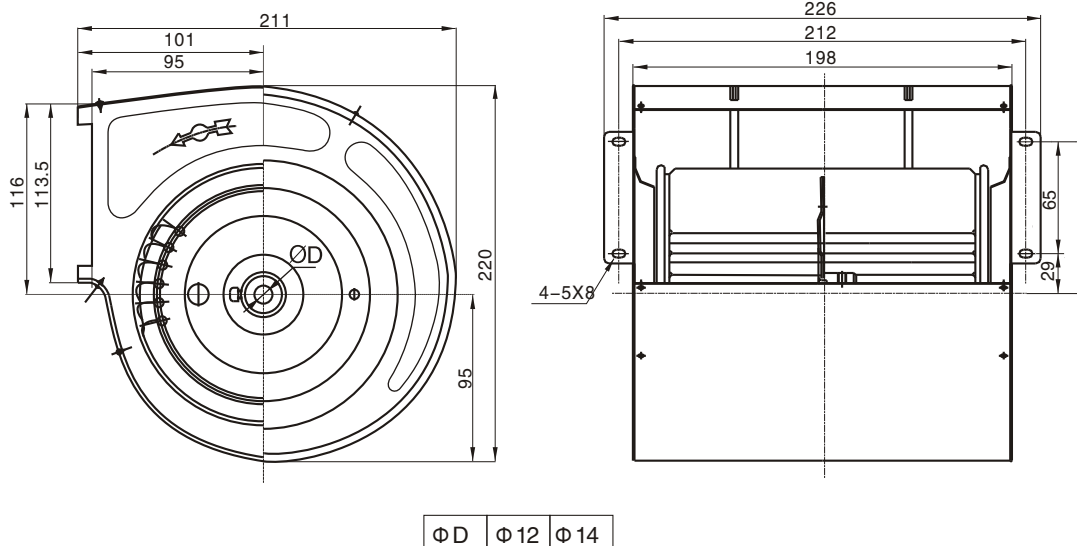

SYP145/160J

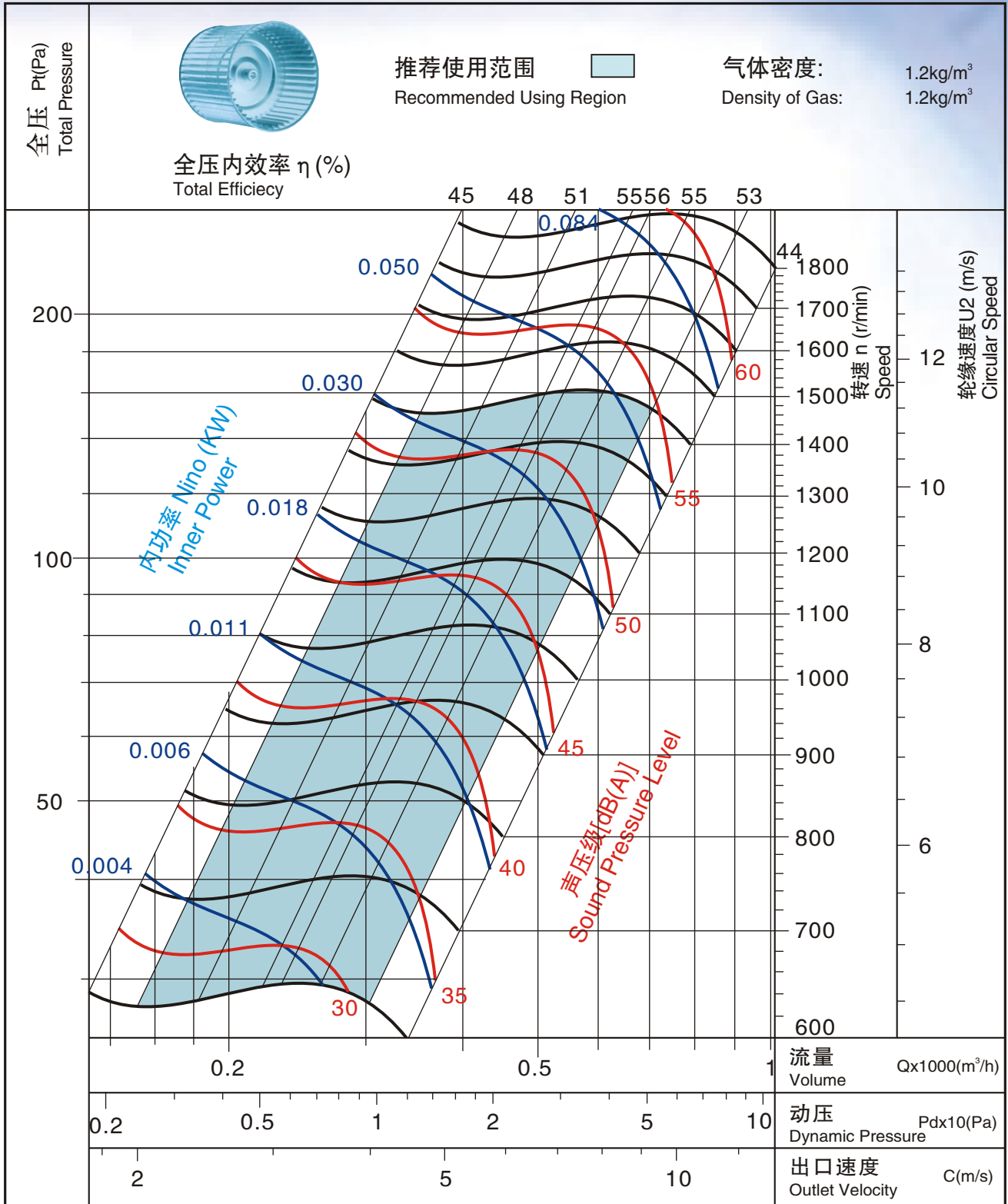

SYP145/190J

推荐使用范围的性能参数

Performance Parameter of Recommended Using Region

转速 Speed r/min	序号 Series No.	风量 Volume m³/h	全压 Total Pressure Pa	静压 Static pressure Pa	内功率 Inner Power W	声压级 Sound Pressure Level dB(A)
700	1	225	38	34	4	32
	2	290	40	32	5	32.5
	3	355	40	28	6	33.5
	4	385	39	27	6.5	34.5
	5	425	38	22	7	35.5
800	1	260	50	44	6	35.5
	2	335	52	42	7	37
	3	410	52	37	9	38
	4	440	51	35	10	38.5
	5	490	50	29	11	39.5
900	1	290	63	56	8.5	39
	2	375	66	53	10.5	39.5
	3	460	66	47	13	41
	4	490	65	44	14	42
	5	550	63	37	15.5	43
1000	1	325	78	69	11	42.5
	2	415	81	65	14	43
	3	510	81	58	17	44
	4	550	80	54	18	45
	5	610	78	46	21	46
1100	1	355	94	84	16	44.5
	2	460	99	80	19	45.5
	3	560	99	70	23	47
	4	600	97	66	25	47.5
	5	670	94	55	29	48
1200	1	390	112	100	20	47
	2	500	117	94	25	48
	3	610	117	84	30	49
	4	660	116	78	33	50
	5	735	112	66	37	51
1300	1	420	131	117	25.5	49
	2	540	138	111	31.5	50.5
	3	660	138	98	38.5	52
	4	710	136	92	41.5	52.5
	5	795	131	77	47	53

外型及安装尺寸 Overall Size and Erection Size

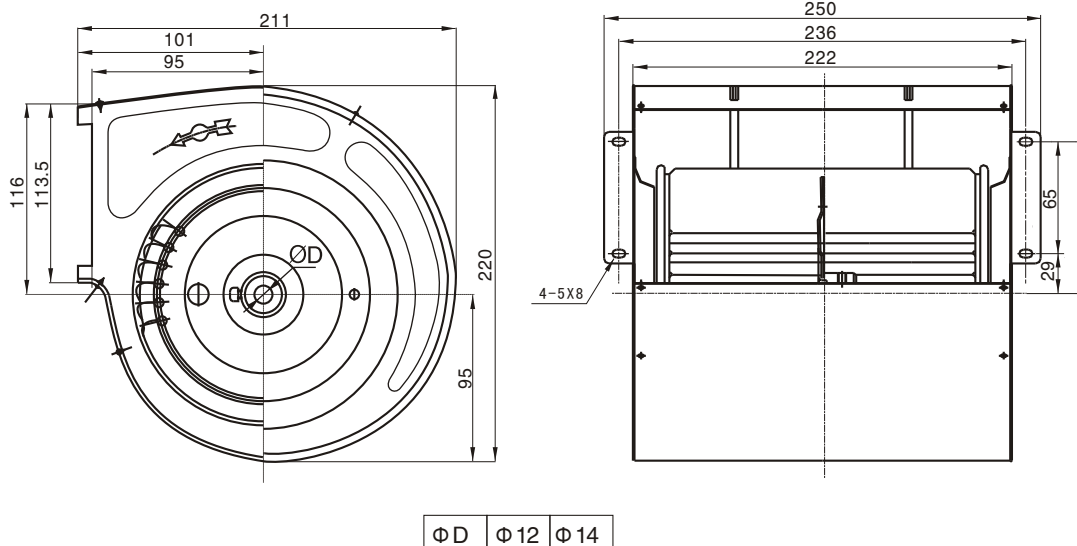

SYP145/190J

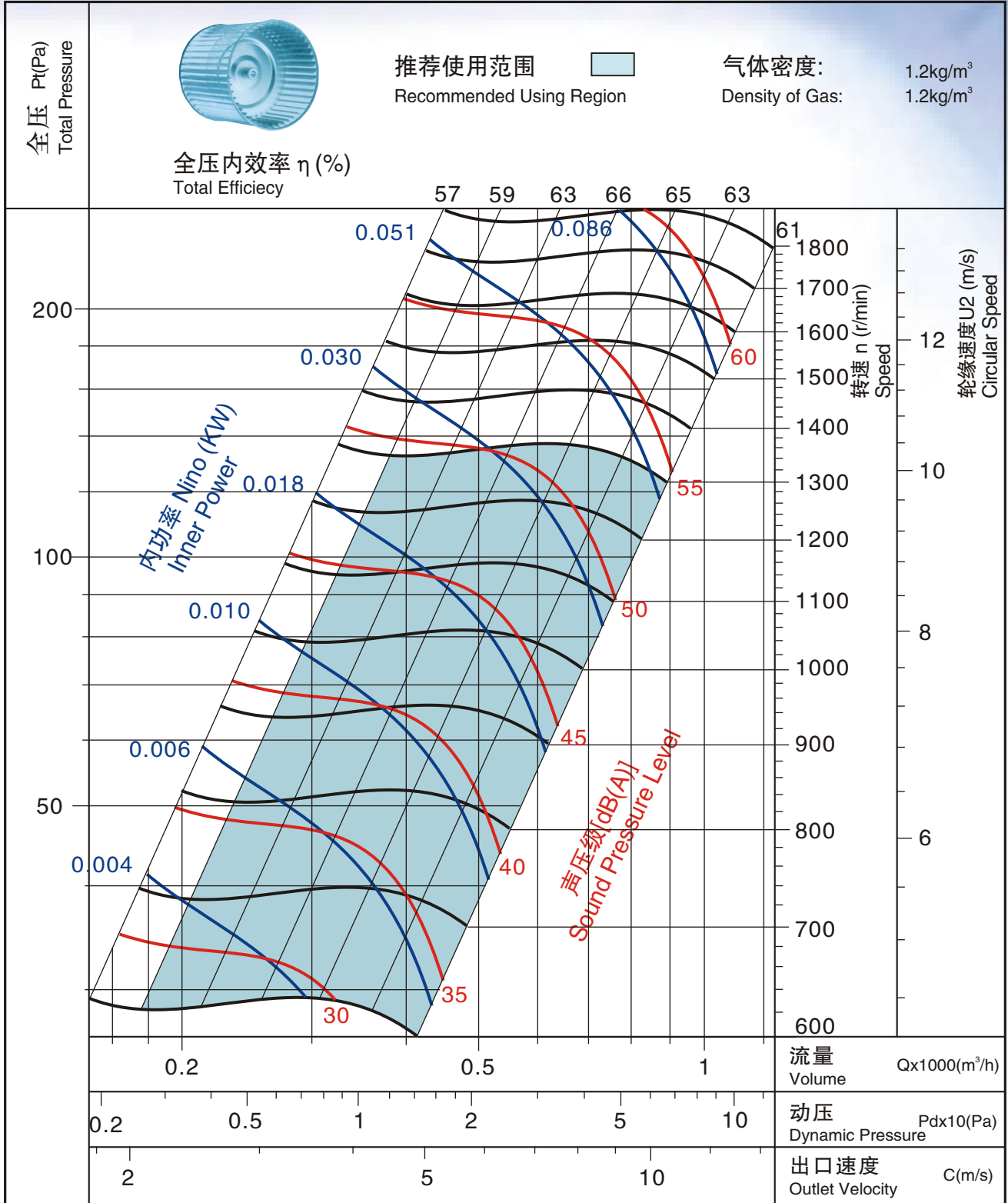

SYP150/150J

推荐使用范围的性能参数

Performance Parameter of Recommended Using Region

转速 Speed r/min	序号 Series No.	风量 Volume m ³ /h	全压 Total Pressure Pa	静压 Static pressure Pa	内功率 Inner Power W	声压级 Sound Pressure Level
700	1	214	37	31	3.2	34
	2	244	35	28	3.6	34
	3	274	34	25	3.9	36
	4	303	33	22	4.3	37
	5	346	32	17	4.9	38
800	1	245	48	40	4.8	37
	2	279	46	36	5.4	38
	3	313	45	32	5.8	39
	4	347	43	28	6.4	40
	5	395	42	22	7.3	42
900	1	275	61	51	7.0	40
	2	314	58	46	7.6	41
	3	352	56	41	8.3	42
	4	390	55	36	9.2	43
	5	445	53	28	10.5	45
1000	1	306	75	63	9.5	43
	2	349	72	57	10.5	44
	3	391	70	51	11.5	45
	4	433	68	44	12.5	46
	5	494	65	35	14.5	47
1100	1	336	90	76	12.5	45
	2	383	87	69	14.0	46
	3	430	84	61	15.1	47
	4	477	82	54	17	48
	5	543	79	42	19	50
1200	1	367	108	91	16.5	48
	2	418	104	82	18.5	48
	3	469	100	73	20	50
	4	520	98	64	22	51
	5	593	94	50	25	52
1300	1	397	126	107	21	50
	2	453	122	96	23	50
	3	508	118	85	25	52
	4	563	115	75	27.5	53
	5	642	110	59	31.5	54

外型及安装尺寸 Overall Size and Erection Size

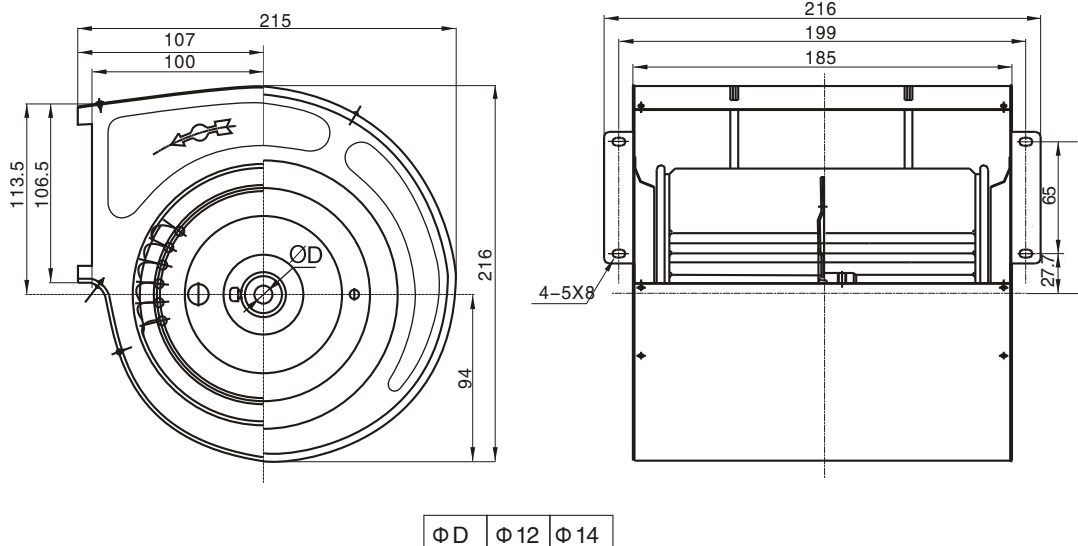

SYP150/150J

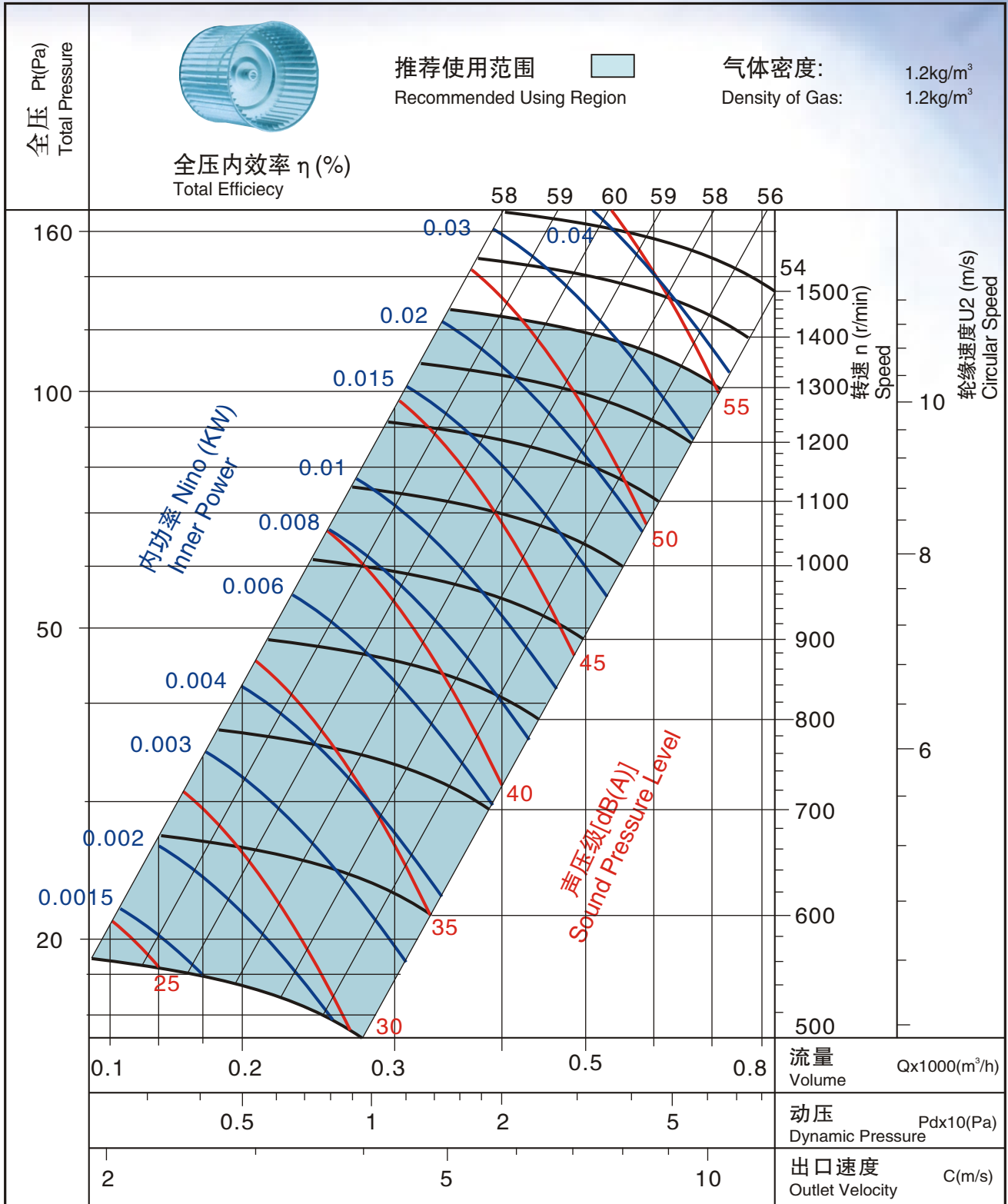

SYP150/200J

推荐使用范围的性能参数

Performance Parameter of Recommended Using Region

转速 Speed r/min	序号 Series No.	风量 Volume m ³ /h	全压 Total Pressure Pa	静压 Static pressure Pa	内功率 Inner Power W	声压级 Sound Pressure Level
700	1	266	39	34	5	33
	2	316	38	30	5.5	34
	3	354	37	27	6.5	35
	4	396	35	22	7.5	37
	5	444	32	16	9	38
800	1	304	52	44	7	37
	2	362	50	40	8.5	37
	3	405	48	35	10	39
	4	452	45	29	11.5	40
	5	507	42	21	13	42
900	1	342	65	56	10.5	40
	2	407	63	50	12	41
	3	455	61	45	14	42
	4	509	57	37	16	44
	5	571	53	27	18.5	45
1000	1	380	80	69	14	43
	2	452	78	62	16.5	43
	3	506	75	55	19	45
	4	565	71	45	22	46
	5	634	65	33	25.5	48
1100	1	418	97	84	20	45
	2	497	95	75	22	46
	3	556	91	67	26	47
	4	622	85	55	29.5	49
	5	698	79	40	34	50
1200	1	455	116	99	24.5	47
	2	542	113	89	28.5	48
	3	607	109	79	33.5	50
	4	678	102	65	38	51
	5	761	94	48	44	52
1300	1	493	136	117	31	50
	2	587	132	105	36	50
	3	658	128	93	42.5	52
	4	735	119	77	48.5	53
	5	824	110	56	56	54

外型及安装尺寸 Overall Size and Erection Size

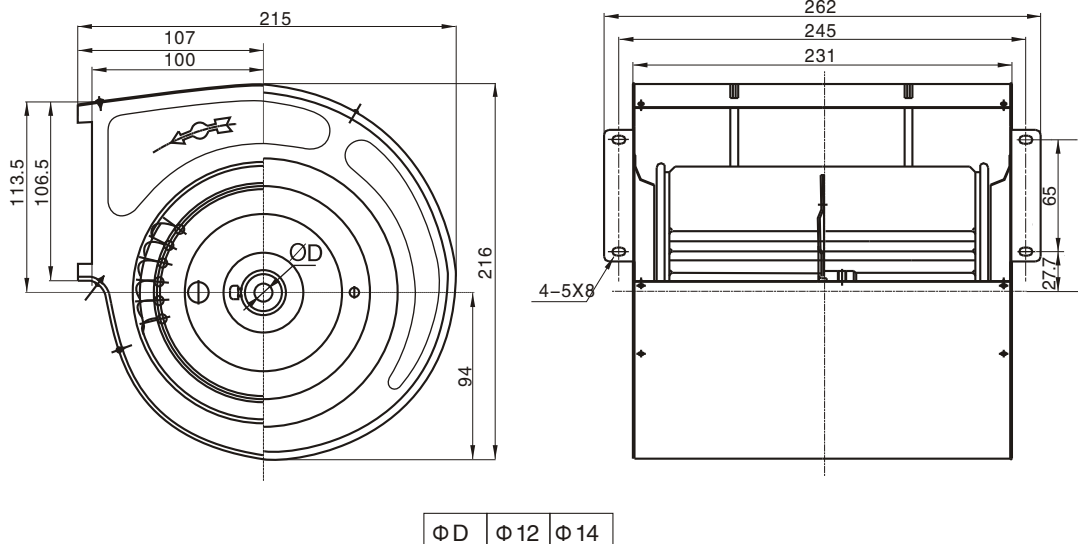

SYP150/200J

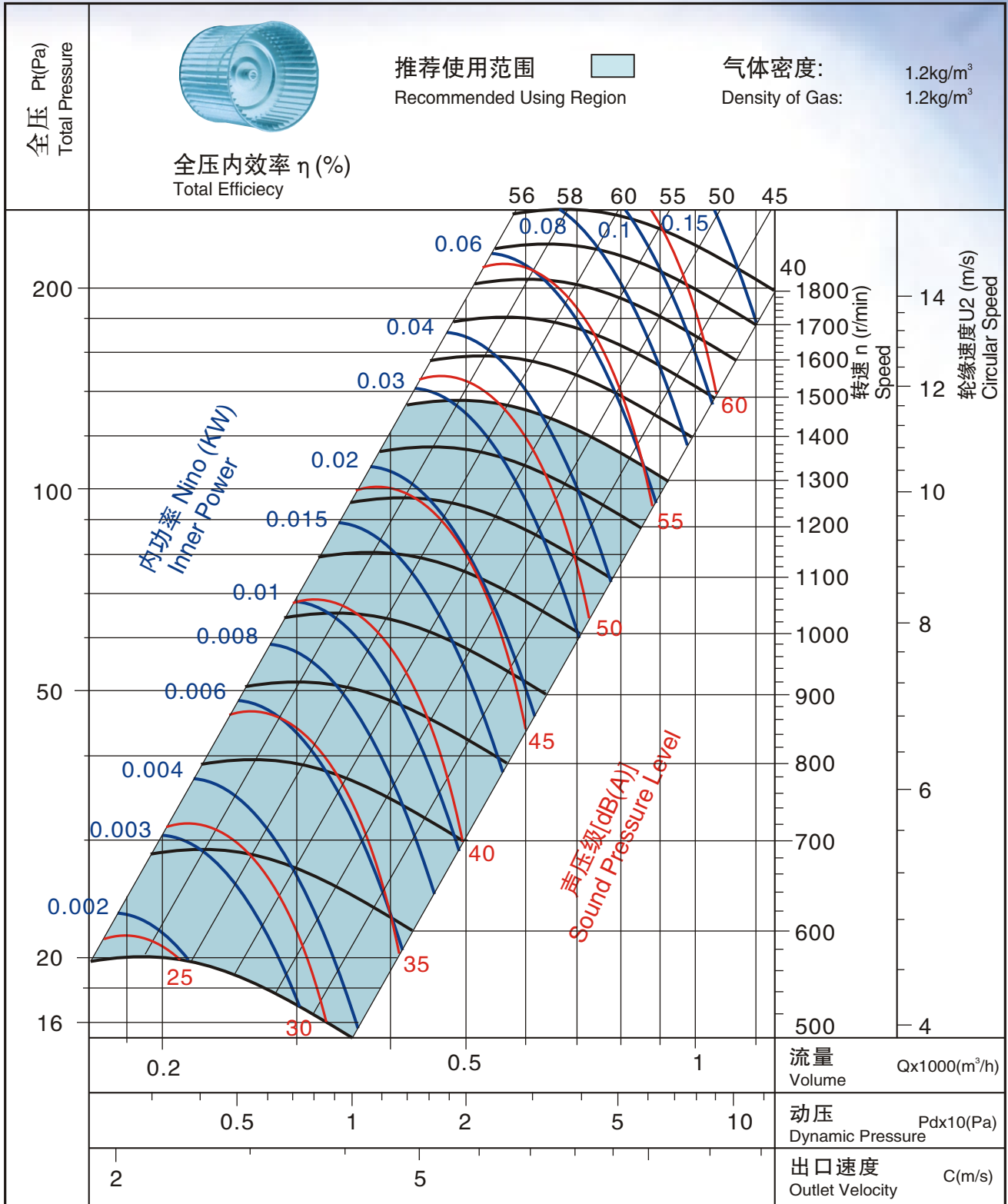

SYP160/160J

推荐使用范围的性能参数

Performance Parameter of Recommended Using Region

转速 Speed r/min	序号 Series No.	风量 Volume m ³ /h	全压 Total Pressure Pa	静压 Static pressure Pa	内功率 Inner Power W	声压级 Sound Pressure Level
700	1	247	46	42	5.5	37
	2	285	47	42	6.5	39
	3	329	46	39	7	39
	4	407	45	34	8.5	41
	5	454	41	28	10	43
800	1	282	60	55	8	40
	2	325	61	54	9.5	42
	3	376	61	51	10.5	42
	4	466	59	44	12.5	45
	5	519	54	36	14.5	46
900	1	317	76	70	12	43
	2	366	78	69	13	45
	3	423	77	65	15	45
	4	524	74	56	18	48
	5	583	68	46	21	49
1000	1	353	94	86	16	46
	2	407	96	85	18	48
	3	470	95	80	20.5	48
	4	582	92	69	24.5	50
	5	648	85	57	28.5	52
1100	1	388	114	104	21	49
	2	447	116	103	24	50
	3	516	114	97	27	51
	4	640	111	84	33	53
	5	713	102	69	38	54
1200	1	423	136	124	28	51
	2	488	138	122	31.5	53
	3	563	136	115	35.5	53
	4	698	132	100	42.5	55
	5	778	122	82	49.5	57

外型及安装尺寸 Overall Size and Erection Size

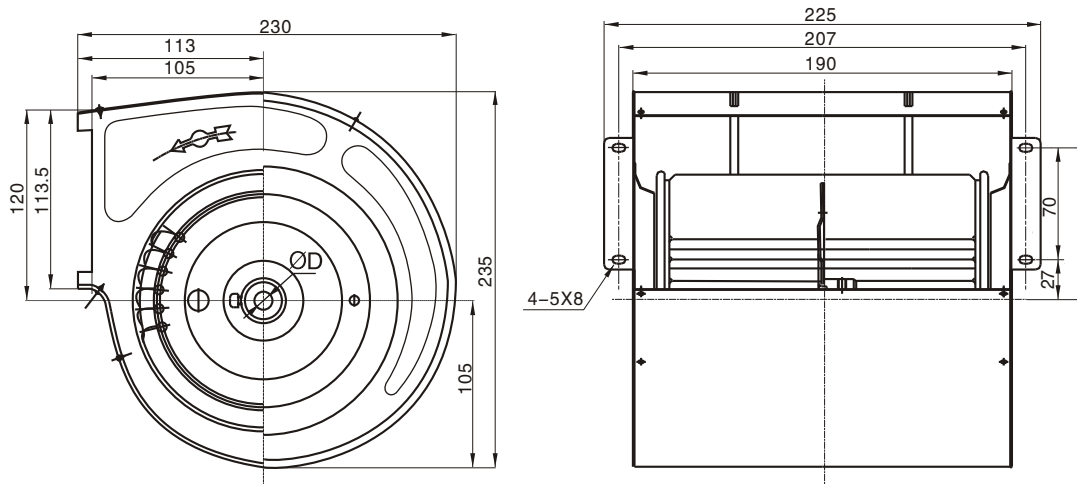

ΦD $\Phi 12$ $\Phi 14$

SYP160/160J

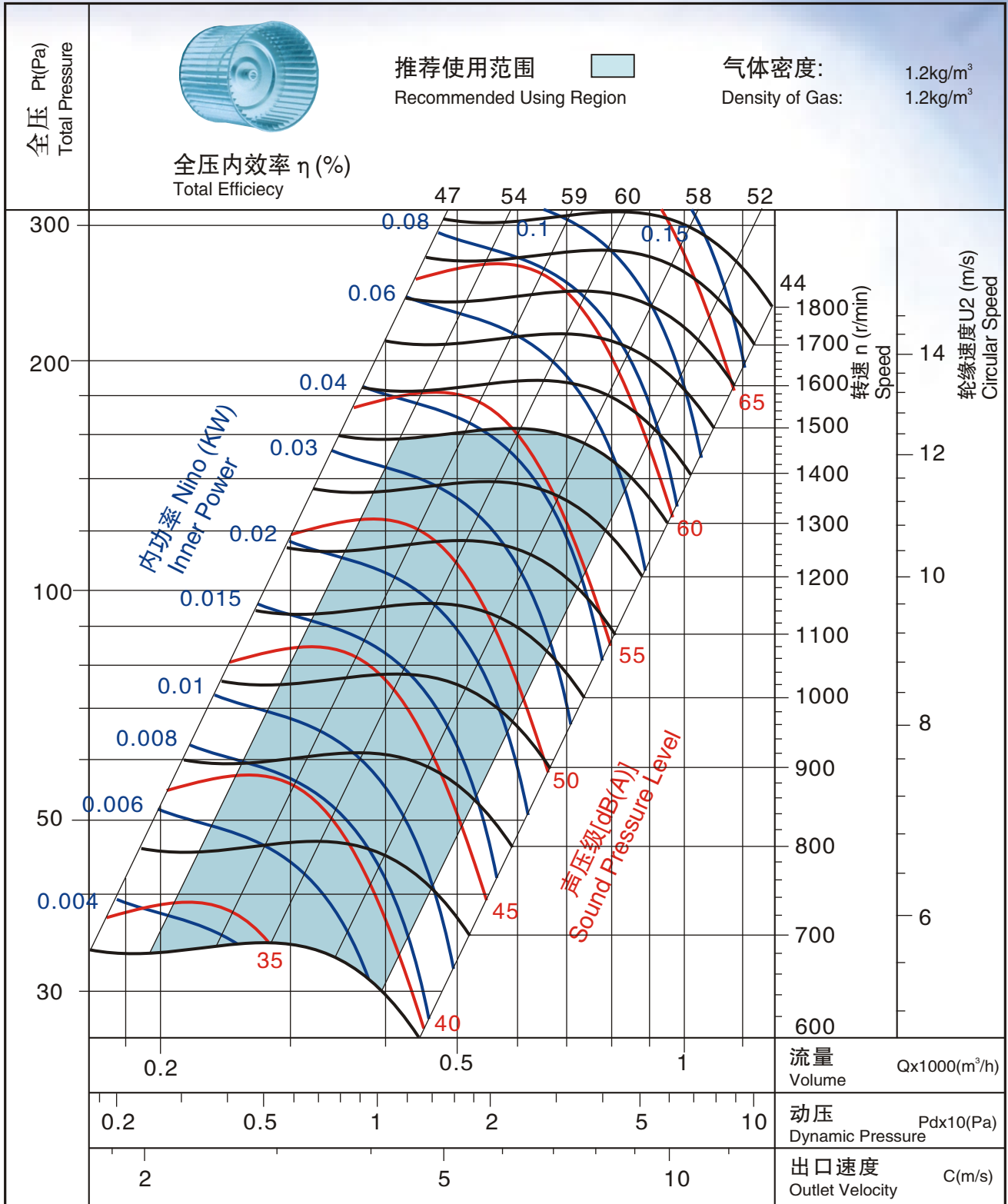

SYP160/200J

推荐使用范围的性能参数

Performance Parameter of Recommended Using Region

转速 Speed r/min	序号 Series No.	风量 Volume m ³ /h	全压 Total Pressure Pa	静压 Static pressure Pa	内功率 Inner Power W	声压级 Sound Pressure Level
700	1	190	45	43	5	35
	2	325	51	43	8	36
	3	390	51	39	9.5	37
	4	445	49	34	11	37.5
	5	525	48	31	12	40
800	1	220	59	56	7	38.5
	2	375	66	56	11.5	39.5
	3	445	66	51	14	40.5
	4	505	64	45	16	42
	5	545	63	40	17.5	42.5
900	1	245	75	71	10	42
	2	420	84	71	16.5	43
	3	500	84	65	20	44
	4	570	81	57	23	44.5
	5	615	80	51	25	45.5
1000	1	270	93	88	14	45
	2	465	104	88	22.5	46
	3	555	104	80	27.5	47
	4	635	100	70	31.5	48
	5	685	99	63	34	48.5
1100	1	300	112	106	18.5	47.5
	2	515	125	106	30	48.5
	3	610	125	97	36.5	49.5
	4	695	121	85	42	50.5
	5	750	120	76	45.5	52
1200	1	325	113	126	24	50
	2	560	149	126	39	52
	3	665	149	116	47.5	52.5
	4	760	144	101	54.5	53
	5	820	142	91	59.5	54

外型及安装尺寸 Overall Size and Erection Size

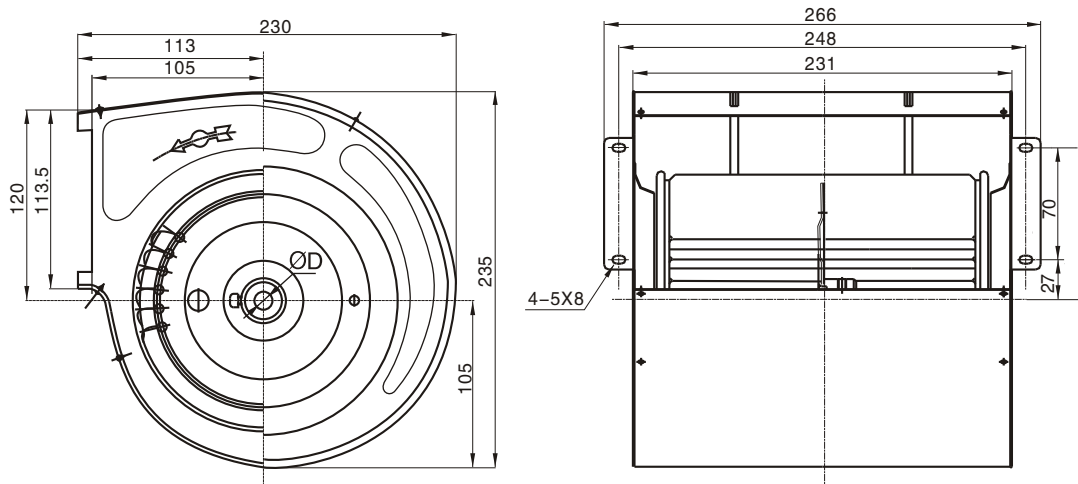

ΦD Φ12 Φ14

SYP160/200J

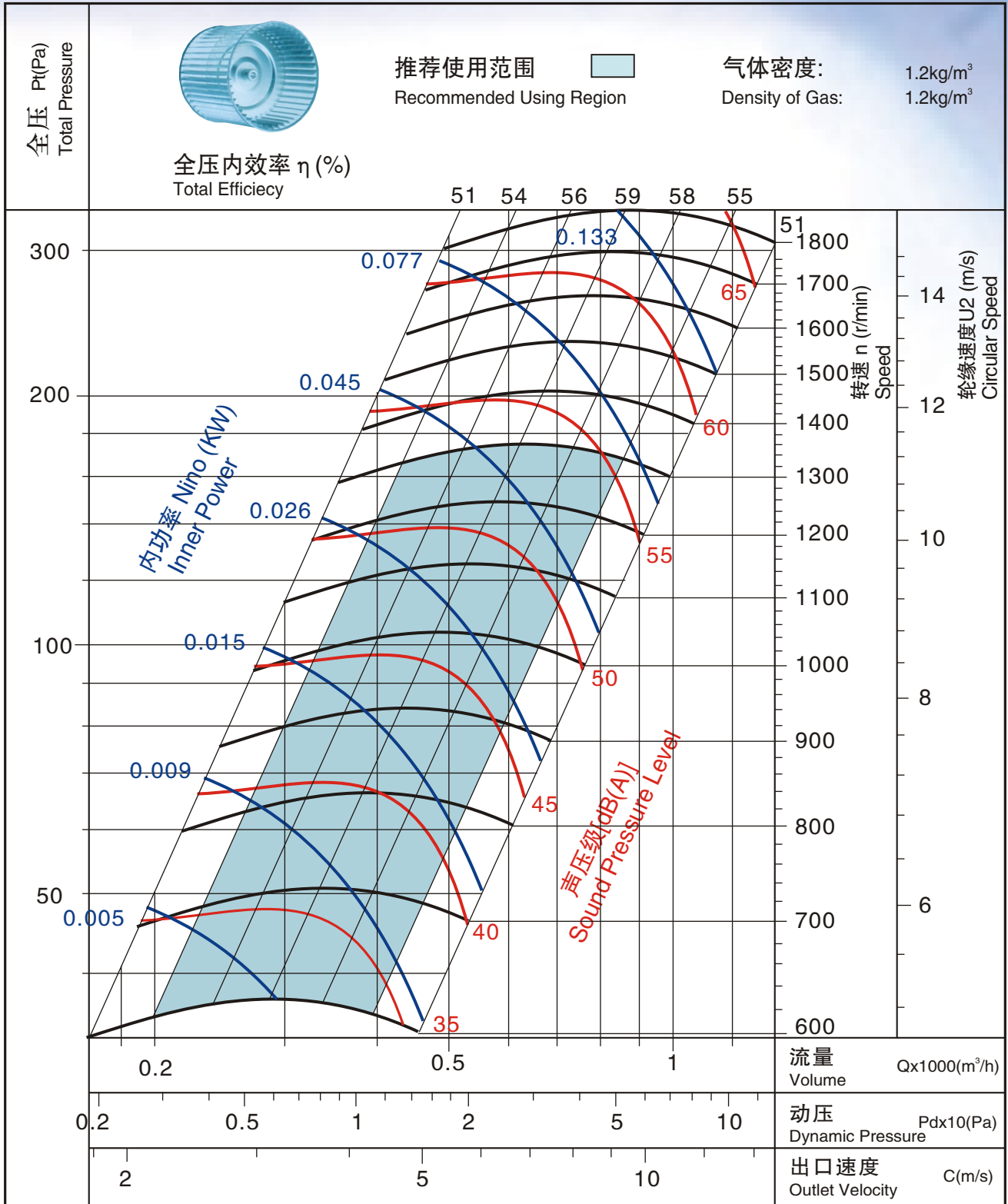

SYP180/200J

推荐使用范围的性能参数

Performance Parameter of Recommended Using Region

转速 Speed r/min	序号 Series No.	风量 Volume m ³ /h	全压 Total Pressure Pa	静压 Static pressure Pa	内功率 Inner Power W	声压级 Sound Pressure Level
700	1	323	56	50	13	38.0
	2	470	54	42	15	41.5
	3	527	54	39	16	42.2
	4	583	53	34	17	42.3
	5	683	48	22	19	45.2
800	1	370	73	65	19	41.5
	2	538	71	55	23	45.0
	3	602	71	50	24	45.7
	4	667	70	45	26	45.8
	5	781	63	29	29	48.7
900	1	416	92	82	27	44.6
	2	605	90	70	32	48.0
	3	678	89	64	35	48.8
	4	750	88	57	37	48.9
	5	879	79	36	41	51.8
1000	1	462	113	102	38	47.3
	2	672	111	86	44	50.8
	3	753	110	79	47	51.6
	4	833	109	70	50	51.6
	5	976	98	45	57	51.5
1100	1	508	137	123	50	49.8
	2	739	134	104	59	53.3
	3	828	134	95	63	54.0
	4	917	131	85	67	54.1
	5	1074	118	54	75	57.0
1200	1	554	163	146	65	52.1
	2	806	160	124	77	55.5
	3	903	159	114	82	56.3
	4	1000	156	101	87	56.4
	5	1172	141	65	98	59.3
1300	1	601	192	172	82	54.2
	2	874	188	145	97	57.6
	3	979	186	133	104	58.3
	4	1083	184	118	110	58.5
	5	1269	165	76	125	61.4

外型及安装尺寸 Overall Size and Erection Size

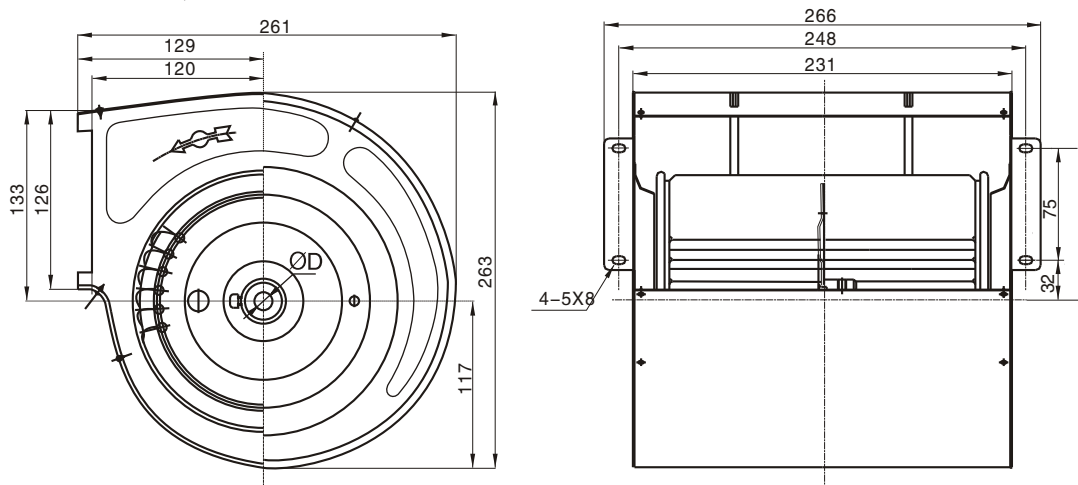

ØD Ø12.7 Ø15

SYP180/200J

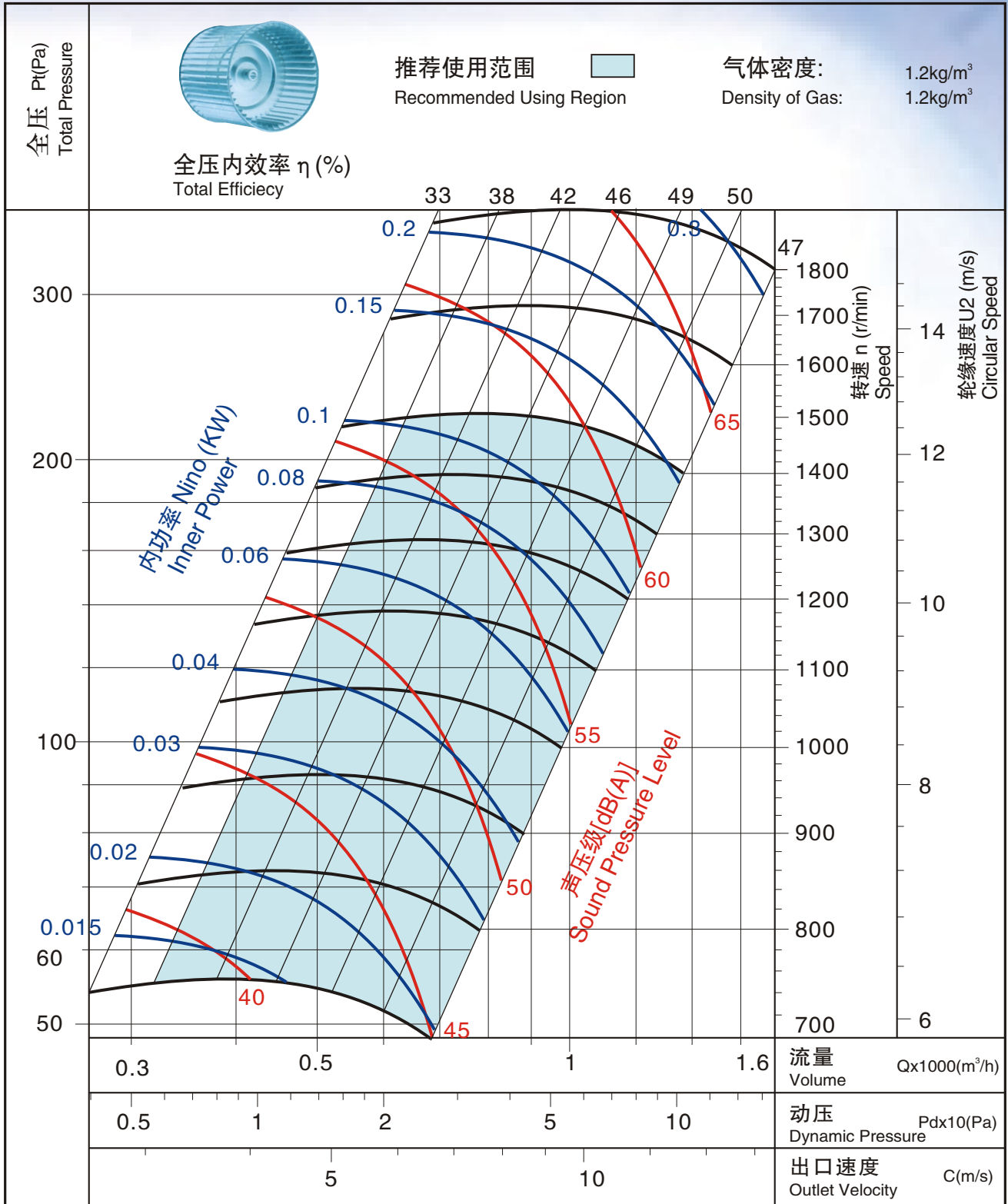

SYP200/190J

推荐使用范围的性能参数

Performance Parameter of Recommended Using Region

转速 Speed r/min	序号 Series No.	风量 Volume m ³ /h	全压 Total Pressure Pa	静压 Static pressure Pa	内功率 Inner Power W	声压级 Sound Pressure Level
700	1	714	83	73	30	45.2
	2	930	77	60	36	47.6
	3	1109	67	43	42	50.7
	4	1314	60	27	51	53.6
	5	1481	49	6	61	55.9
800	1	816	108	95	44	49.9
	2	1063	101	79	53	52.9
	3	1267	87	56	62	55.0
	4	1502	79	35	75	57.6
	5	1693	63	7	91	62.7
900	1	918	137	120	63	53.0
	2	1196	127	100	76	53.0
	3	1426	110	70	89	58.1
	4	1689	100	44	107	60.7
	5	1904	80	9	130	65.7
1000	1	1020	169	148	87	55.7
	2	1329	157	123	104	58.7
	3	1584	136	87	122	60.8
	4	1877	123	54	147	63.4
	5	2116	99	12	178	68.5
1100	1	1122	204	179	116	58.2
	2	1461	190	149	139	61.2
	3	1743	164	105	162	63.3
	4	2065	149	66	196	65.9
	5	2327	120	14	237	71.0
1200	1	1224	243	214	150	60.5
	2	1594	227	177	180	63.5
	3	1901	196	125	210	65.6
	4	2253	177	78	254	68.2
	5	2539	143	17	308	73.2
1300	1	1326	285	251	191	62.6
	2	1727	266	208	229	65.5
	3	2060	230	147	267	67.6
	4	2440	208	92	323	70.3
	5	2750	167	20	391	75.3

外型及安装尺寸 Overall Size and Erection Size

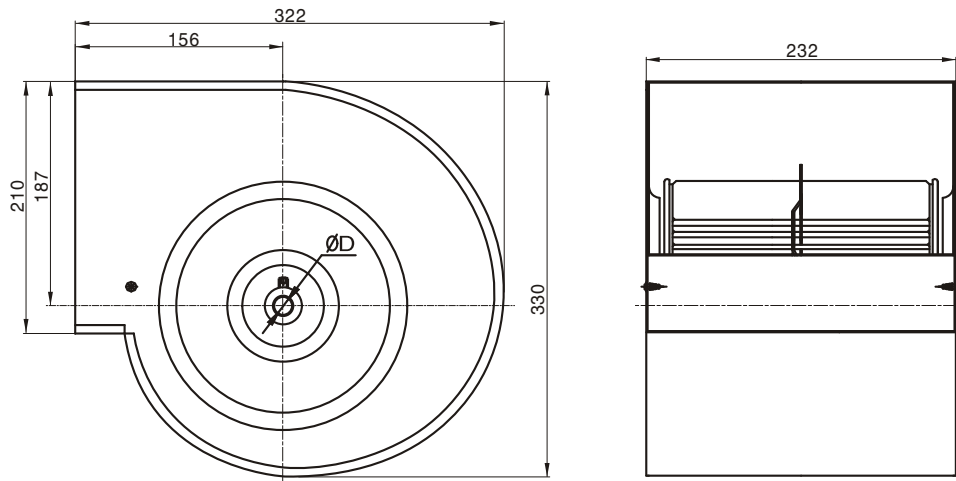

ΦD Φ12.7 Φ15

SYP200/190J

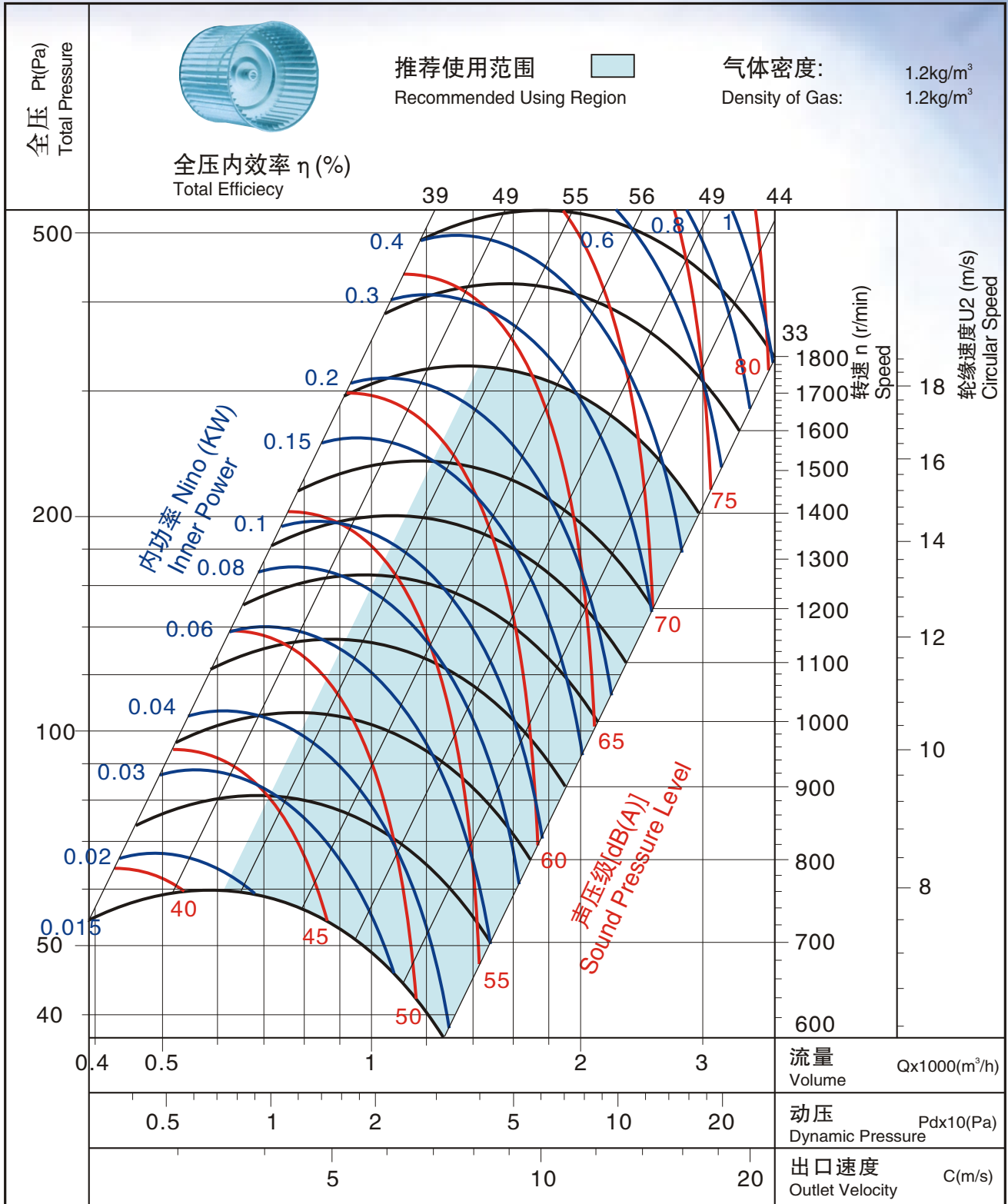

SYP200/190J-1

推荐使用范围的性能参数

Performance Parameter of Recommended Using Region

转速 Speed r/min	序号 Series No.	风量 Volume m ³ /h	全压 Total Pressure Pa	静压 Static pressure Pa	内功率 Inner Power W	声压级 Sound Pressure Level
700	1	463	79	66	18.5	43
	2	573	79	59	21	45
	3	633	77	52	22.5	45
	4	687	74	45	24	46
	5	750	70	36	26.5	48
800	1	529	103	86	28	47
	2	655	103	77	31.5	48
	3	723	100	68	33.5	49
	4	786	97	58	36	50
	5	857	92	47	39.5	51
900	1	595	130	108	39.5	50
	2	737	130	97	44.5	51
	3	813	127	86	48	52
	4	884	122	74	51.5	53
	5	964	116	59	56	54
1000	1	661	161	134	54	52
	2	819	161	120	61	54
	3	904	157	106	65.5	55
	4	982	151	91	70.5	56
	5	1072	144	73	77	57
1100	1	728	195	162	72	55
	2	900	195	145	81	56
	3	994	190	128	87	57
	4	1080	183	110	93.5	58
	5	1179	174	88	102	59
1200	1	794	231	193	93.5	57
	2	982	232	172	105.5	59
	3	1085	226	153	113	59
	4	1179	217	131	121.5	60
	5	1286	207	105	132.5	62
1300	1	860	272	226	119	59
	2	1064	272	202	134	61
	3	1175	265	179	144	61
	4	1277	255	154	154.5	63
	5	1393	243	123	168.5	64

外型及安装尺寸 Overall Size and Erection Size

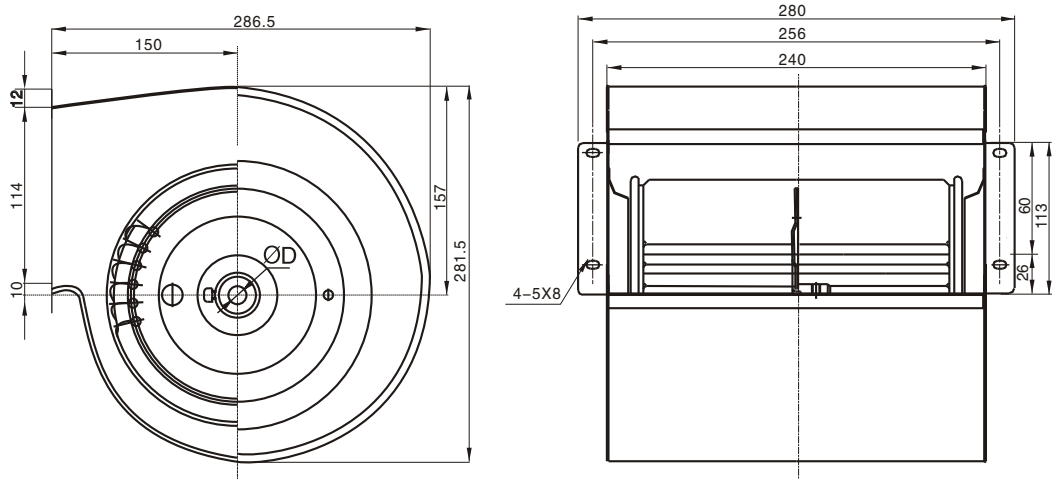

ΦD Φ12.7 Φ15

SYP200/190J-1

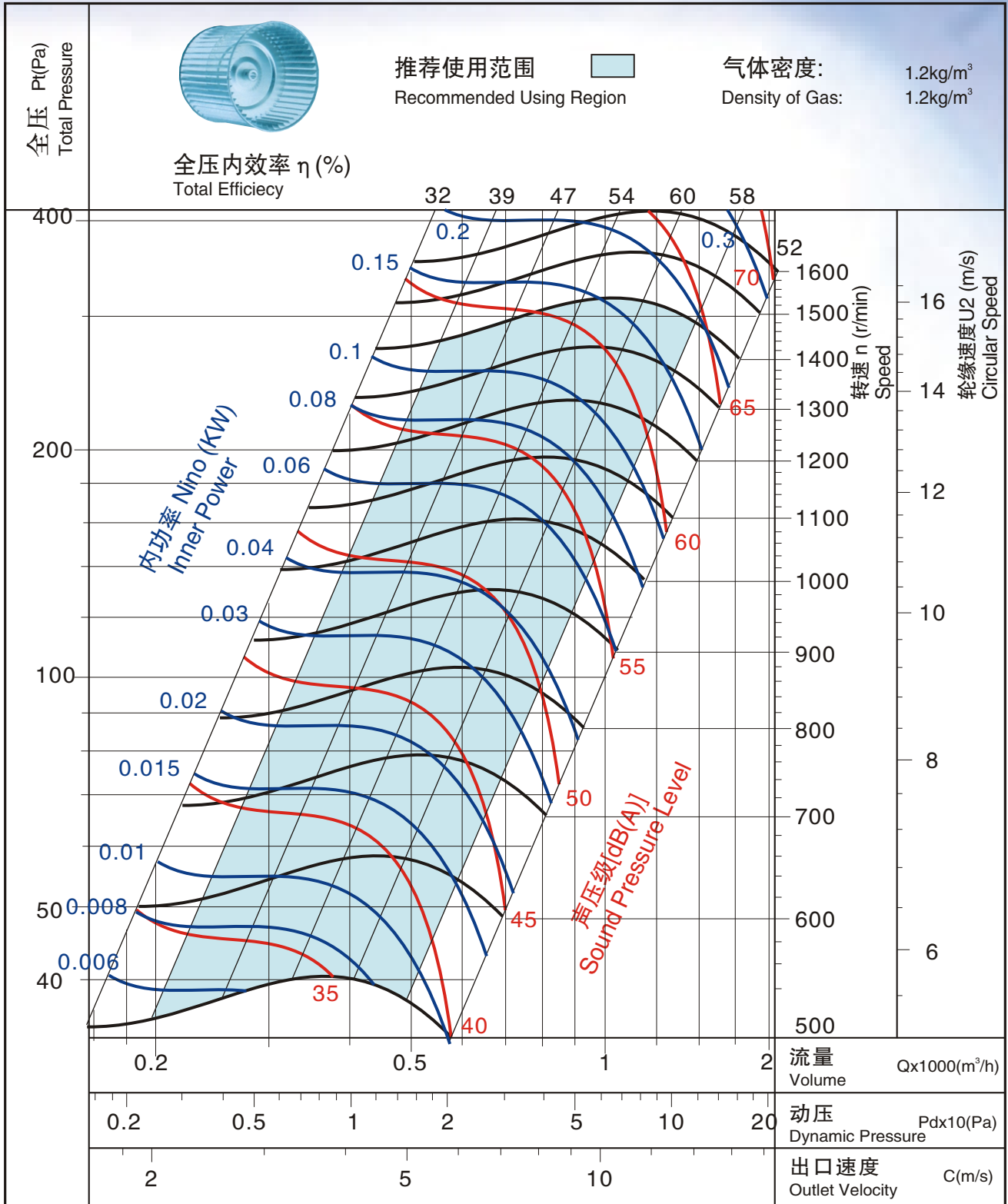

SYP200/190J-2

推荐使用范围的性能参数

Performance Parameter of Recommended Using Region

转速 Speed	序号 Series	风量 Volume	全压 Total Pressure	静压 Static pressure	内功率 Inner Power	声压级 Sound Pressure Level
r/min	No.	m ³ /h	Pa	Pa	W	Level
700	1	507	82	69	25	40.9
	2	685	83	59	29	42.7
	3	807	81	48	34	44.2
	4	907	79	38	37	45.9
	5	1004	75	24	41	48.6
800	1	580	107	90	37	44.4
	2	782	108	77	44	46.1
	3	922	106	63	51	47.7
	4	1036	103	49	56	49.5
	5	1147	98	32	61	51.9
900	1	652	135	114	52	47.5
	2	880	137	98	62	49.2
	3	1037	134	80	72	50.7
	4	1166	130	62	79	52.4
	5	1291	124	40	87	54.7
1000	1	725	167	140	72	50.2
	2	978	169	121	86	51.9
	3	1152	165	99	99	53.4
	4	1295	161	77	109	55.2
	5	1434	153	50	119	57.7
1100	1	797	202	170	96	52.7
	2	1076	204	146	114	54.4
	3	1268	200	119	132	55.9
	4	1425	195	93	145	57.7
	5	1578	185	60	158	60.2
1200	1	869	240	202	124	54.9
	2	1173	243	174	148	56.7
	3	1383	238	142	171	58.2
	4	1554	232	111	188	59.9
	5	1721	220	72	206	62.6
1300	1	942	282	237	158	57.0
	2	1271	285	204	188	58.8
	3	1498	279	167	218	60.2
	4	1684	272	130	240	62.0
	5	1865	258	84	261	64.7

外型及安装尺寸 Overall Size and Erection Size

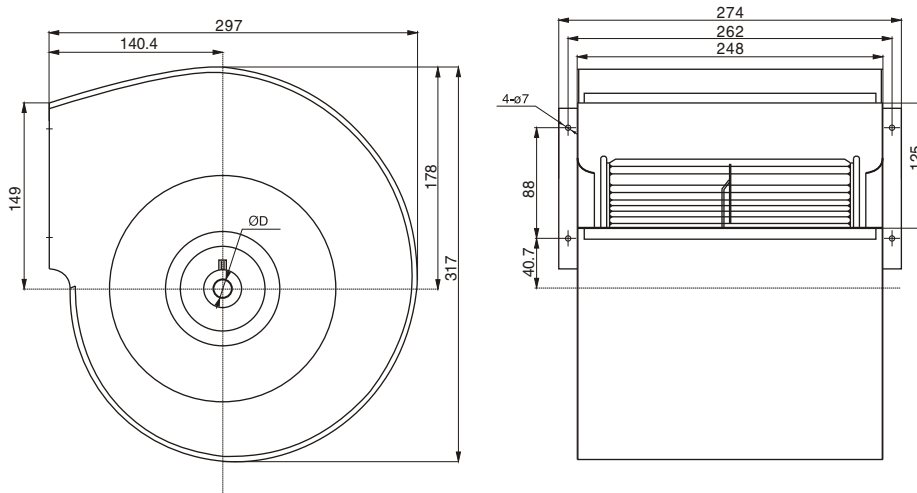

ΦD Φ12.7 Φ15

SYP200/190J-2

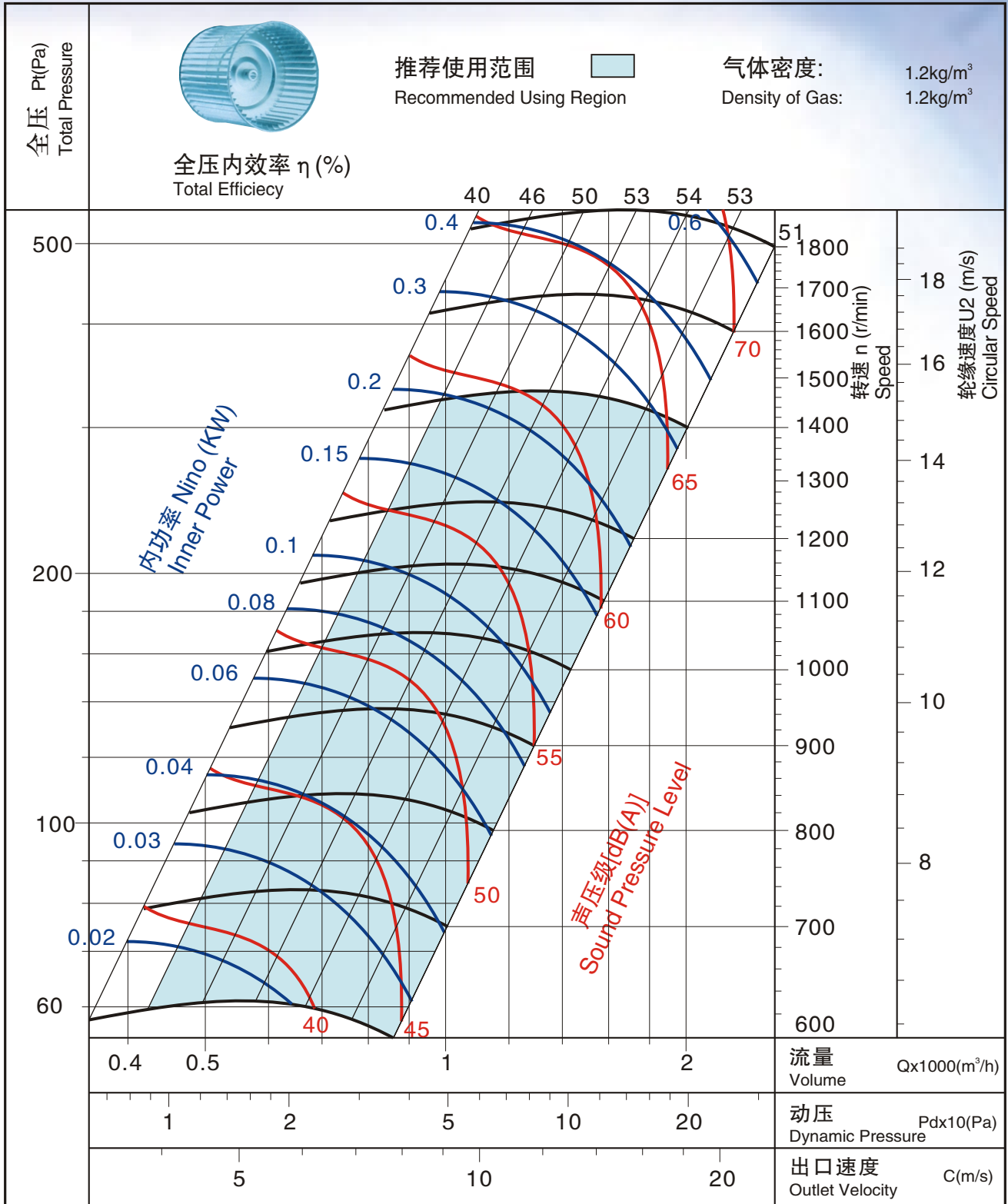

SYP200/190J-3

推荐使用范围的性能参数

Performance Parameter of Recommended Using Region

转速 Speed	序号 Series	风量 Volume	全压 Total Pressure	静压 Static pressure	内功率 Inner Power	声压级 Sound Pressure Level
r/min	No.	m ³ /h	Pa	Pa	W	dB(A)
700	1	415	77	68	25	41.0
	2	587	85	66	29	42.1
	3	777	91	58	35	43.7
	4	872	92	51	39	44.8
	5	1019	95	37	46	47.5
800	1	474	101	88	37	44.6
	2	671	111	86	43	45.8
	3	888	119	75	53	47.0
	4	997	121	66	58	48.3
	5	1165	123	49	69	50.9
900	1	534	127	112	52	47.7
	2	754	140	109	61	48.6
	3	999	150	95	75	50.2
	4	1121	153	84	83	51.4
	5	1310	156	62	98	53.9
1000	1	593	157	138	71	50.5
	2	838	173	134	84	51.4
	3	1110	185	117	103	53.0
	4	1246	189	103	114	54.2
	5	1456	193	76	134	56.9
1100	1	652	190	167	95	52.9
	2	922	209	162	112	54.0
	3	1221	224	142	137	55.3
	4	1370	228	125	152	56.6
	5	1602	233	92	179	59.2
1200	1	711	227	199	123	55.2
	2	1006	249	193	146	56.1
	3	1332	267	169	178	57.6
	4	1495	272	149	197	58.9
	5	1747	278	110	232	61.5
1300	1	771	266	233	157	57.3
	2	1090	292	227	185	58.2
	3	1444	313	198	227	59.6
	4	1620	319	174	250	60.9
	5	1893	326	129	295	63.7
1400	1	830	308	270	196	59.2
	2	1174	339	263	231	60.0
	3	1555	363	230	283	61.7
	4	1744	370	202	313	62.9
	5	2038	378	150	368	65.3

外型及安装尺寸 Overall Size and Erection Size

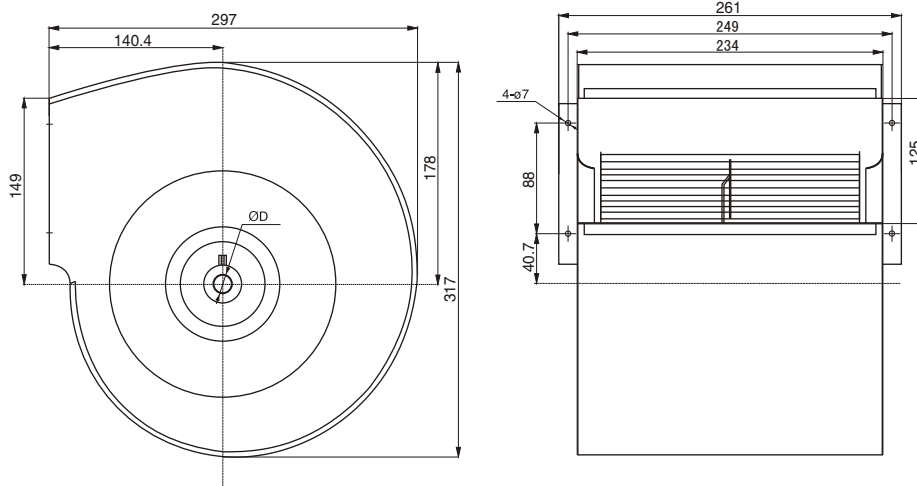

ΦD Φ12.7 Φ15 Φ17

SYP200/190J-3

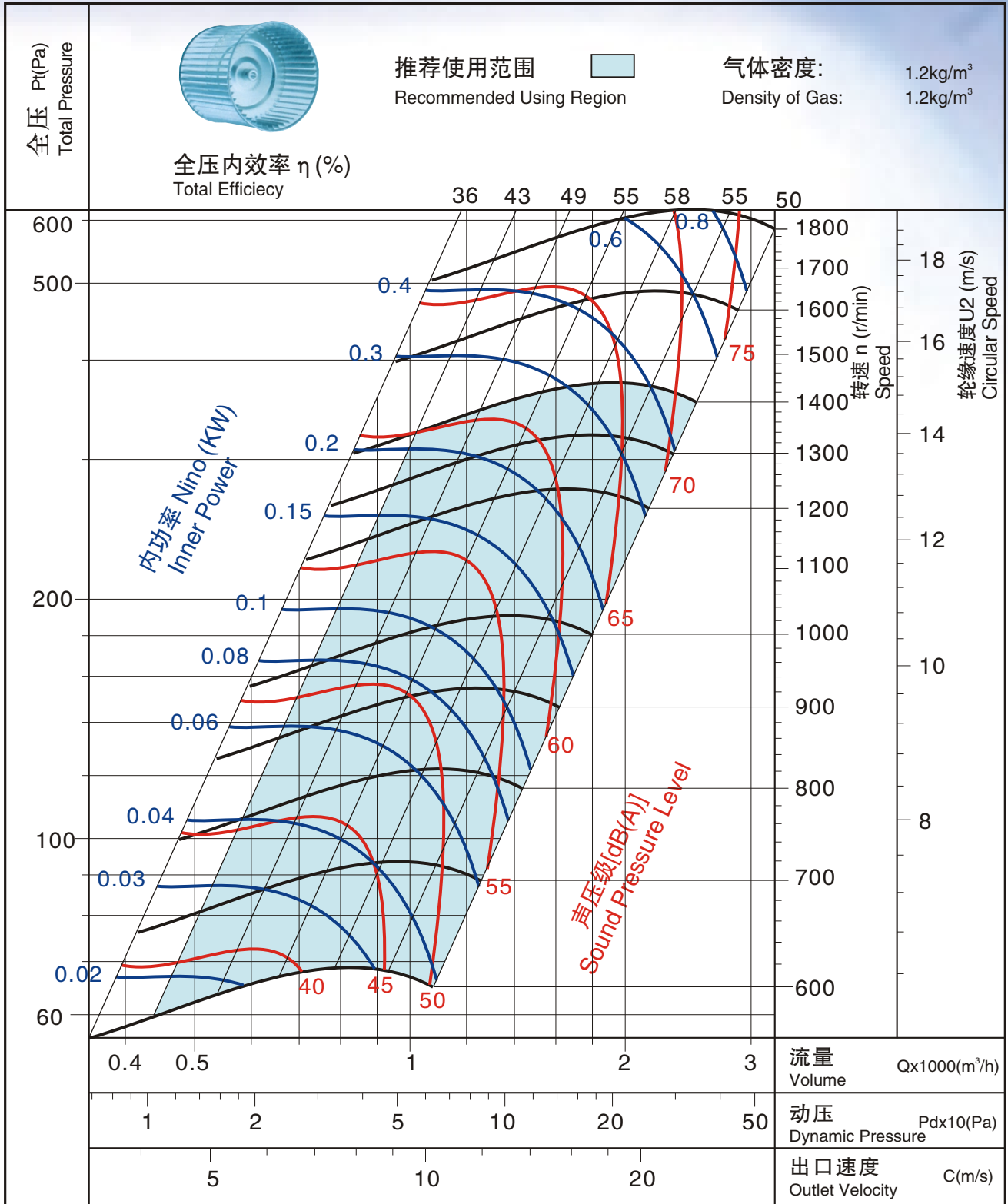

SYP225/200J

推荐使用范围的性能参数

Performance Parameter of Recommended Using Region

转速 Speed	序号 Series	风量 Volume	全压 Total Pressure	静压 Static pressure	内功率 Inner Power	声压级 Sound Pressure Level
r/min	No.	m ³ /h	Pa	Pa	W	Level
700	1	334	86	83	27	44.3
	2	518	95	86	32	43.9
	3	758	106	87	40	45.0
	4	932	108	79	46	46.5
	5	1022	108	72	52	47.5
800	1	382	113	108	41	47.8
	2	592	124	112	48	47.4
	3	867	139	114	59	48.4
	4	1065	141	103	69	49.9
	5	1168	141	95	77	51.0
900	1	430	143	137	58	50.9
	2	666	157	142	68	50.4
	3	975	176	144	84	51.5
	4	1198	179	130	98	53.0
	5	1314	178	120	110	54.1
1000	1	478	176	169	80	53.6
	2	740	193	175	93	53.2
	3	1083	217	178	116	54.3
	4	1331	221	161	135	55.8
	5	1460	220	148	151	56.8
1100	1	526	213	204	106	56.1
	2	814	234	212	124	55.7
	3	1192	263	215	154	56.7
	4	1464	267	195	179	58.2
	5	1606	266	179	201	59.3
1200	1	573	254	243	137	58.4
	2	888	278	252	161	57.9
	3	1300	313	256	200	59.0
	4	1597	318	232	233	60.5
	5	1752	317	213	261	61.6
	1	621	298	285	175	60.5
	2	962	327	296	205	60.0
	3	1408	367	300	254	61.1
	4	1731	373	272	296	62.6
	5	1898	372	250	332	63.7

外型及安装尺寸 Overall Size and Erection Size

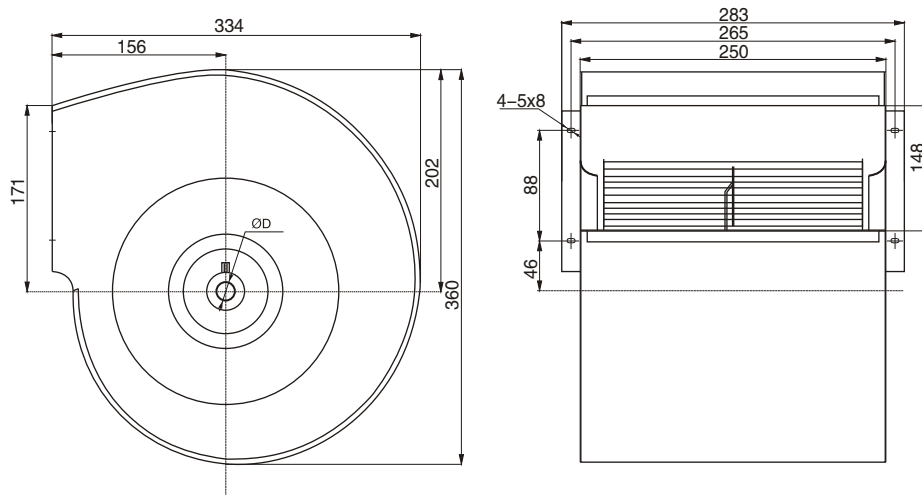

ΦD Φ12.7 Φ15

SYP225/200J

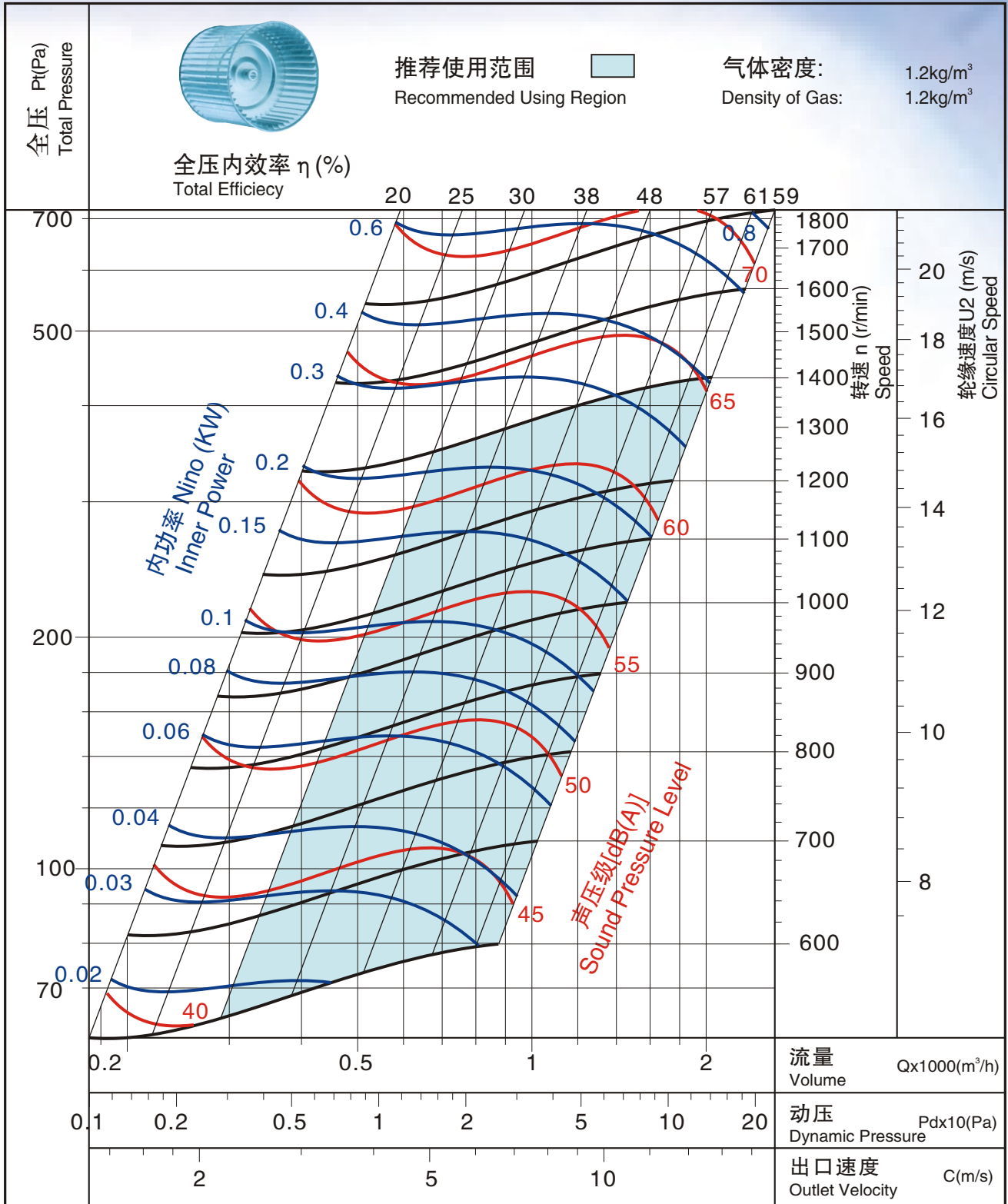

SYP225/250J

推荐使用范围的性能参数

Performance Parameter of Recommended Using Region

转速 Speed r/min	序号 Series No.	风量 Volume m³/h	全压 Total Pressure Pa	静压 Static pressure Pa	内功率 Inner Power W	声压级 Sound Pressure Level dB(A)
700	1	849	103	86	46	43.8
	2	1079	107	80	57	45.6
	3	1370	105	61	62	47.8
	4	1559	101	44	87	50.0
	5	1828	92	14	114	53.2
800	1	970	134	112	69	47.3
	2	1233	140	104	86	49.1
	3	1566	137	79	93	51.3
	4	1782	132	58	131	53.5
	5	2089	121	18	170	56.6
900	1	1092	170	142	98	50.4
	2	1388	177	132	122	52.2
	3	1761	173	100	132	54.4
	4	2004	167	73	186	56.6
	5	2350	153	23	242	59.7
1000	1	1213	210	175	134	53.1
	2	1542	218	162	168	54.9
	3	1957	214	124	181	57.1
	4	2227	207	90	255	59.3
	5	2611	188	28	331	62.5
1100	1	1334	254	212	178	55.6
	2	1696	264	197	223	57.4
	3	2153	259	150	241	59.6
	4	2450	250	109	339	61.8
	5	2872	228	34	441	64.9
1200	1	1456	302	252	232	57.9
	2	1850	314	234	289	59.7
	3	2348	308	179	313	61.8
	4	2673	298	130	441	64.1
	5	3134	271	41	573	67.2
1300	1	1577	355	296	294	60.0
	2	2004	369	275	368	61.8
	3	2544	362	210	398	63.9
	4	2895	349	153	560	66.2
	5	3395	318	48	728	69.3

外型及安装尺寸 Overall Size and Erection Size

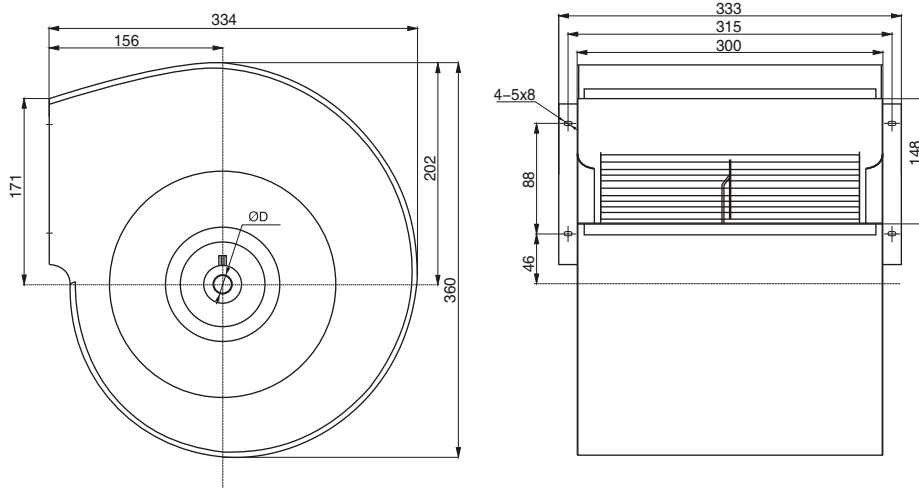

ΦD Φ12.7 Φ15

SYP225/250J

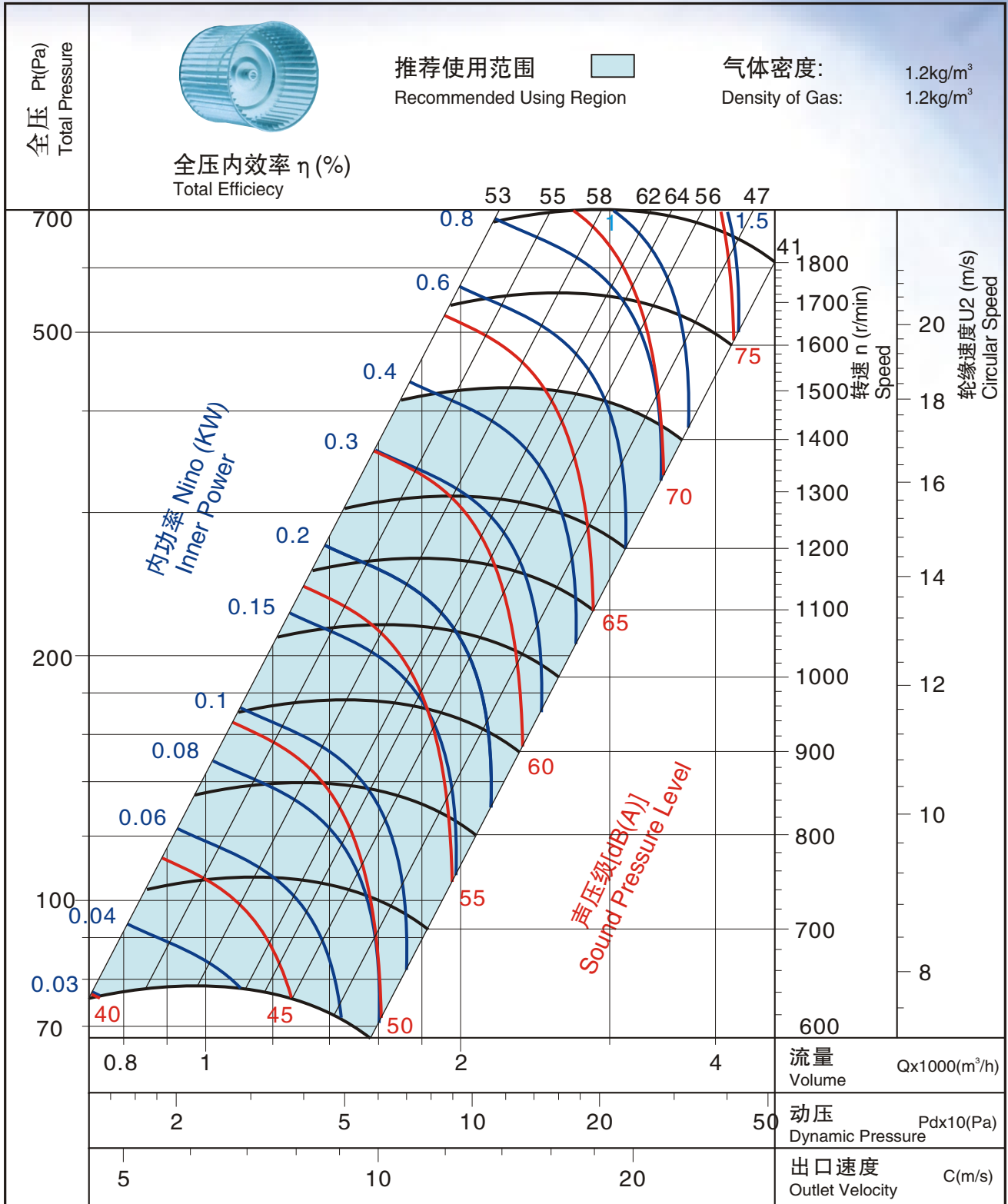

SYP250/190J

推荐使用范围的性能参数

Performance Parameter of Recommended Using Region

转速 Speed r/min	序号 Series No.	风量 Volume m³/h	全压 Total Pressure Pa	静压 Static pressure Pa	内功率 Inner Power W	声压级 Sound Pressure level
700	1	739	122	115	44	46.5
	2	1053	127	113	63	49.4
	3	1218	127	109	73	51.5
	4	1361	125	102	84	54.1
	5	1649	112	78	112	59.2
800	1	845	159	150	66	49.9
	2	1203	166	147	94	52.9
	3	1392	166	142	108	55.0
	4	1555	163	133	125	57.6
	5	1885	147	102	168	62.7
900	1	950	202	190	93	53.0
	2	1354	210	187	135	53.0
	3	1566	210	179	154	58.1
	4	1750	207	168	178	60.7
	5	2120	186	129	239	65.7
1000	1	1056	249	235	128	55.7
	2	1504	259	230	185	58.7
	3	1740	259	221	211	60.8
	4	1944	255	208	244	63.4
	5	2356	229	160	328	68.5
1100	1	1161	301	287	171	58.2
	2	1655	313	279	246	61.2
	3	1914	314	268	281	63.3
	4	2139	309	251	325	65.9
	5	2591	277	193	436	71.0
1200	1	1267	359	338	222	60.5
	2	1805	373	332	319	63.5
	3	2088	374	319	365	65.6
	4	2333	367	299	422	68.2
	5	2827	330	230	567	73.2
1300	1	1372	421	397	282	62.6
	2	1956	437	389	405	65.5
	3	2262	438	374	464	67.6
	4	2528	431	351	537	70.3
	5	3026	387	270	720	75.3

外型及安装尺寸 Overall Size and Erection Size

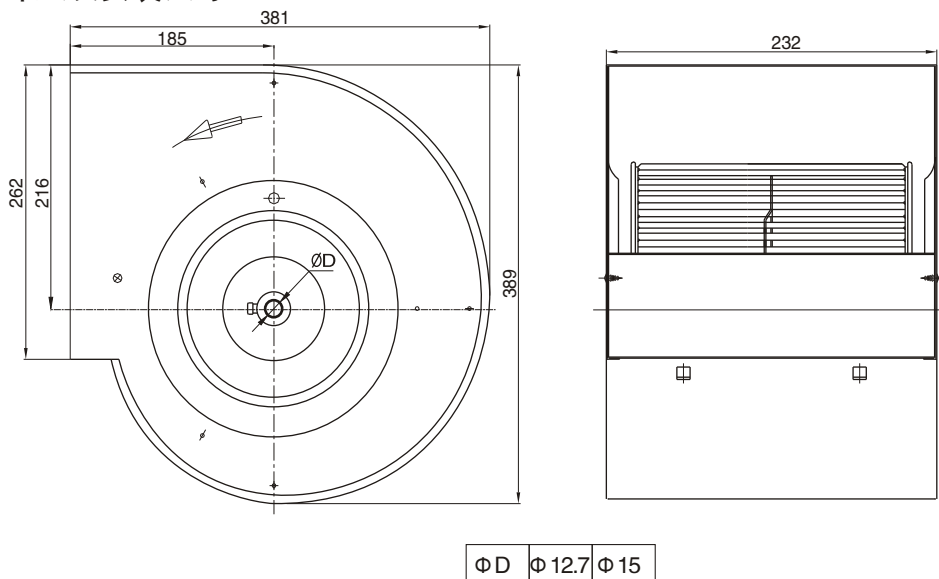

SYP250/190J

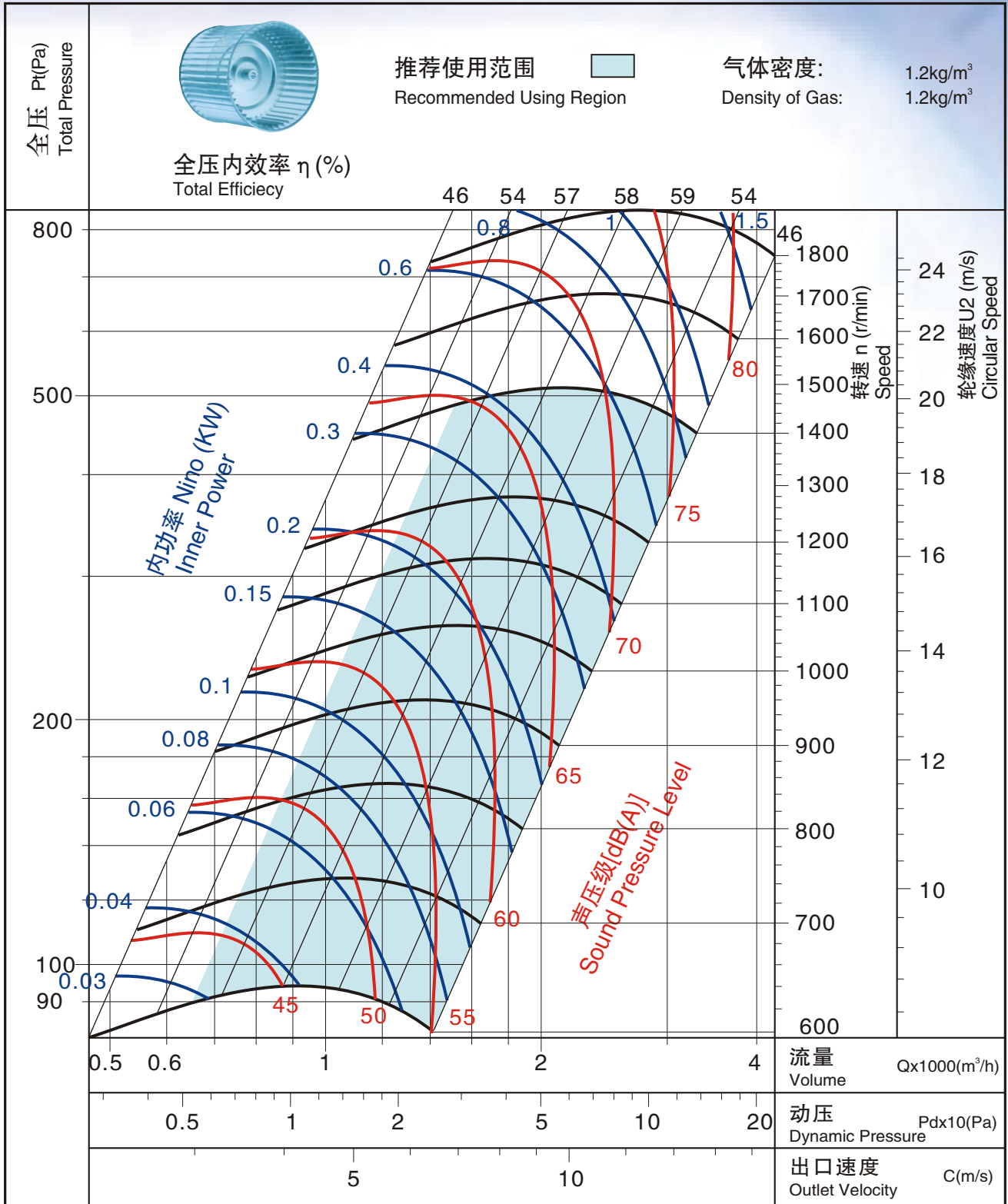

SYP250/190J-1

推荐使用范围的性能参数

Performance Parameter of Recommended Using Region

转速 Speed	序号 Series	风量 Volume	全压 Total Pressure	静压 Static pressure	内功率 Inner Power	声压级 Sound Pressure level
r/min	No.	m ³ /h	Pa	Pa	W	
700	1	943	116	101	53	47.9
	2	1143	117	94	65	49.6
	3	1363	113	81	84	52.2
	4	1672	107	59	112	54.2
	5	1901	100	38	142	56.4
800	1	1078	152	132	79	51.3
	2	1306	152	123	97	53.1
	3	1557	147	106	125	55.6
	4	1911	140	78	168	57.7
	5	2173	131	50	211	59.9
900	1	1213	192	167	113	54.4
	2	1469	193	156	138	56.2
	3	1752	186	134	178	58.7
	4	2149	177	98	239	60.8
	5	2444	166	64	301	62.9
1000	1	1347	237	206	155	57.1
	2	1632	238	192	189	58.9
	3	1947	230	165	244	61.4
	4	2388	219	121	328	63.5
	5	2716	205	78	413	65.8
1100	1	1482	287	250	206	59.6
	2	1796	288	233	252	61.4
	3	2142	278	199	324	63.9
	4	2627	265	147	436	66.0
	5	2987	248	95	549	68.3
1200	1	1617	342	297	267	61.9
	2	1959	342	277	327	63.7
	3	2336	331	237	421	66.2
	4	2866	315	175	567	68.3
	5	3259	295	113	713	70.5
1300	1	1751	401	349	340	64.0
	2	2122	402	325	416	65.7
	3	2531	388	279	535	68.3
	4	3105	370	205	720	70.4
	5	3530	346	133	906	72.3

外型及安装尺寸 Overall Size and Erection Size

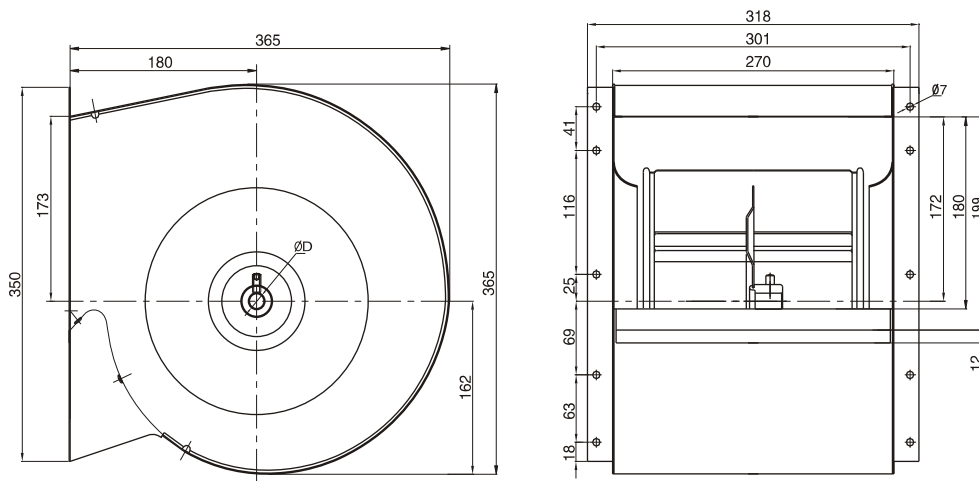

ΦD Φ12.7 Φ15

SYP250/190J-1

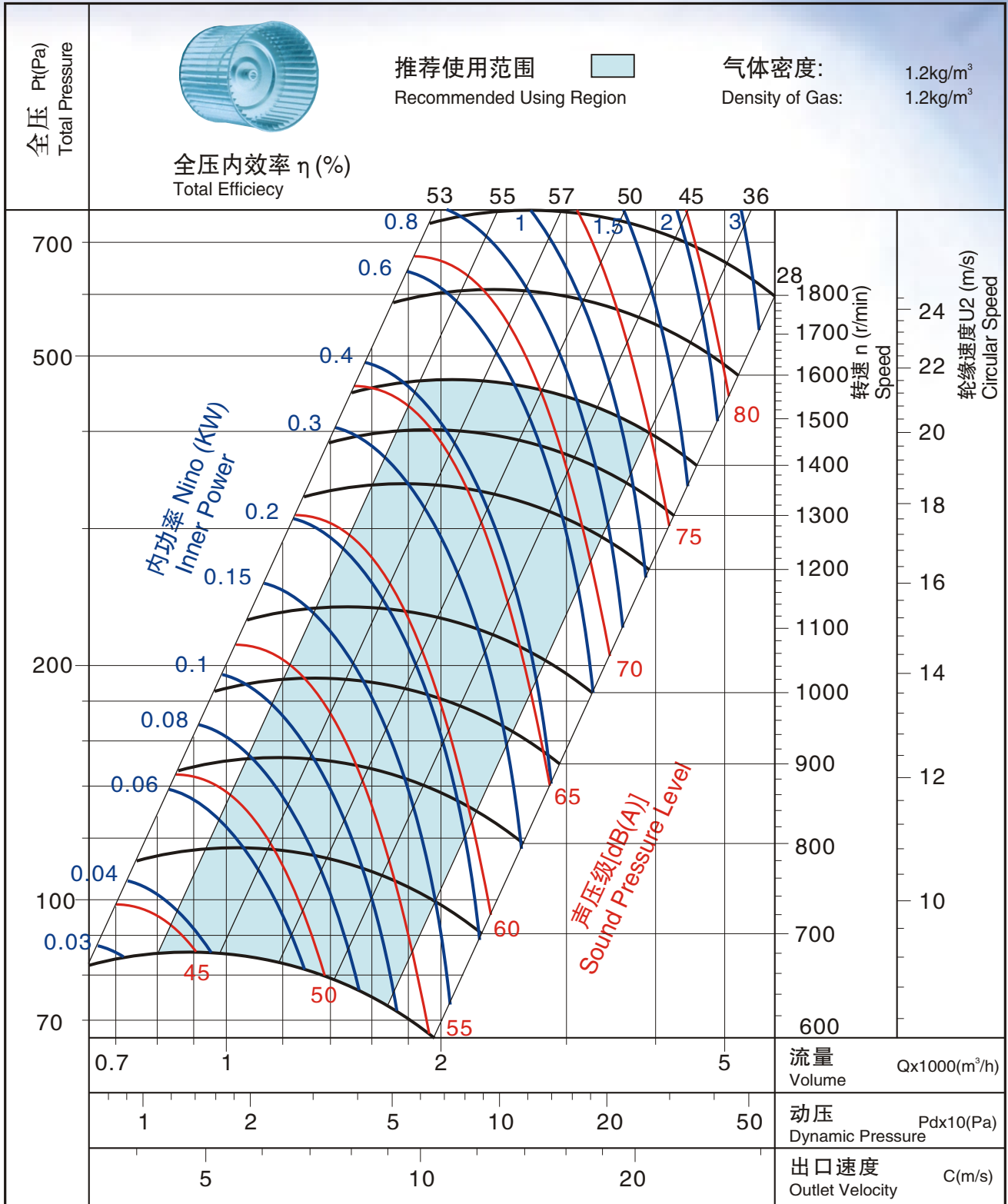

SYP250/250J

推荐使用范围的性能参数

Performance Parameter of Recommended Using Region

转速 Speed	序号 Series	风量 Volume	全压 Total Pressure	静压 Static pressure	内功率 Inner Power	声压级 Sound Pressure level
r/min	No.	m ³ /h	Pa	Pa	W	dB(A)
700	1	1034	111	103	58	47.6
	2	1254	123	111	70	48.8
	3	1496	122	105	84	50.4
	4	1633	119	99	97	52.3
	5	1773	113	89	111	54.4
800	1	1182	145	135	87	50.7
	2	1433	161	145	105	52.3
	3	1710	159	137	125	53.9
	4	1866	156	129	145	55.8
	5	2026	148	117	165	57.9
900	1	1329	184	171	124	53.8
	2	1612	204	184	150	55.4
	3	1923	202	174	179	57.0
	4	2100	197	164	207	58.9
	5	2280	187	148	235	60.9
1000	1	1477	227	211	170	56.6
	2	1791	251	227	205	58.1
	3	2137	249	215	245	59.7
	4	2333	243	202	284	61.6
	5	2533	231	183	322	63.7
1100	1	1625	275	255	226	59.0
	2	1971	304	275	273	60.6
	3	2351	301	260	326	62.2
	4	2566	294	245	378	64.2
	5	2786	279	221	429	66.2
1200	1	1773	327	303	293	61.3
	2	2150	362	327	355	62.9
	3	2565	359	309	423	64.5
	4	2799	350	291	490	66.4
	5	3039	332	263	557	68.4
1300	1	1920	384	356	372	63.4
	2	2329	425	384	451	64.9
	3	2778	421	363	538	66.6
	4	3033	411	342	624	68.5
	5	3293	390	308	708	70.5
1400	1	2068	445	413	465	65.3
	2	2508	493	445	564	66.9
	3	2992	488	421	672	68.5
	4	3566	476	396	779	70.5
	5	3546	452	358	884	72.5

外型及安装尺寸 Overall Size and Erection Size

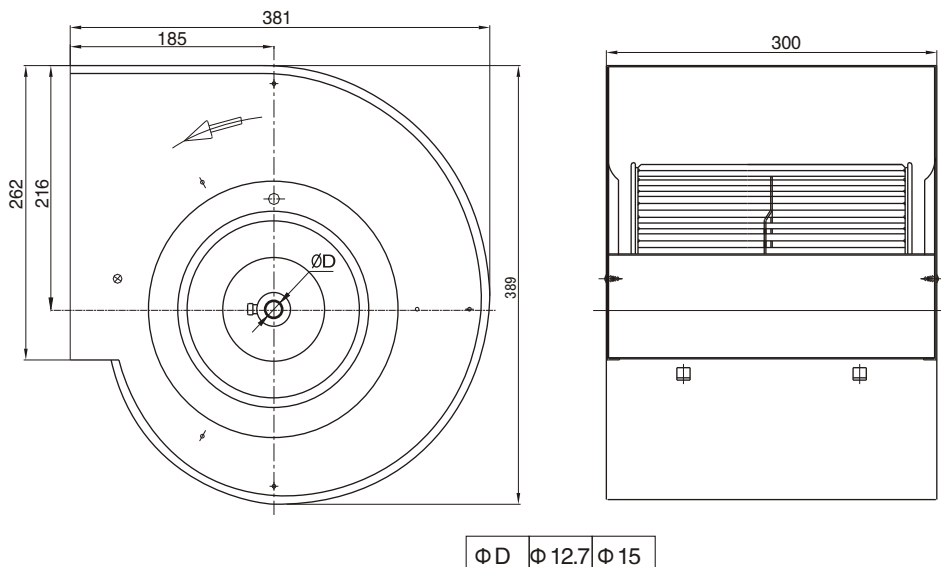

SYP250/250J

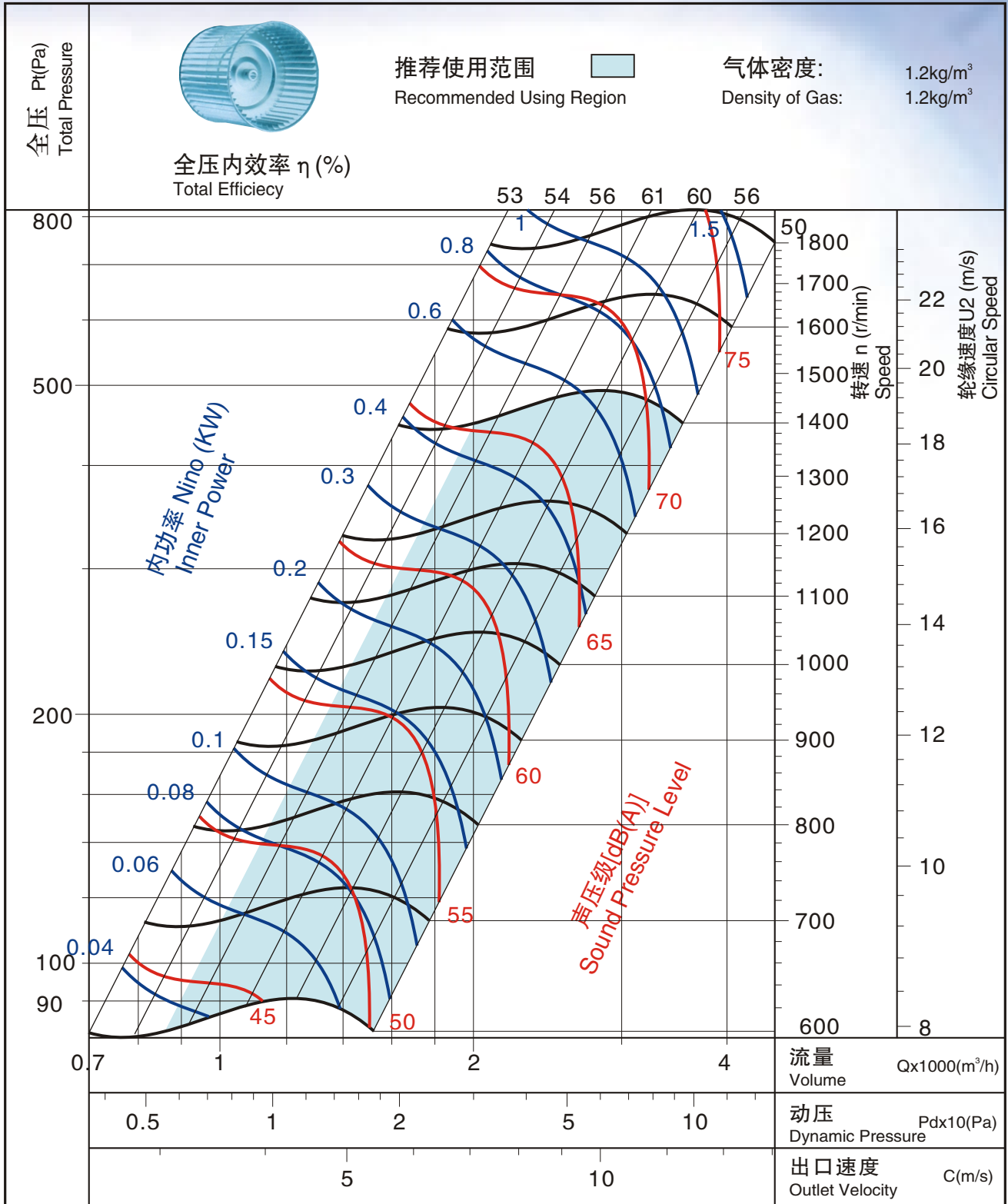

SYP250/250J-1

推荐使用范围的性能参数

Performance Parameter of Recommended Using Region

转速 Speed	序号 Series	风量 Volume	全压 Total Pressure	静压 Static pressure	内功率 Inner Power	声压级 Sound Pressure level
r/min	No.	m ³ /h	Pa	Pa	W	
700	1	1015	120	108	58	47.6
	2	1257	124	106	72	48.8
	3	1470	121	97	88	50.4
	4	1614	120	90	104	52.3
	5	1825	118	80	135	54.4
800	1	1159	157	142	86	52.0
	2	1436	161	138	108	52.9
	3	1680	158	127	132	55.0
	4	1844	156	118	156	56.2
	5	2086	154	105	202	57.7
900	1	1304	199	179	122	55.1
	2	1616	204	175	154	56.0
	3	1891	201	160	188	58.1
	4	2075	198	149	222	59.2
	5	2347	195	132	287	62.1
1000	1	1449	245	221	168	57.9
	2	1795	252	216	211	58.8
	3	2101	248	198	258	60.8
	4	2305	244	184	304	62.0
	5	2607	240	164	394	64.8
1100	1	1594	297	268	223	60.3
	2	1975	305	261	281	61.2
	3	2311	300	239	343	63.3
	4	2536	295	223	404	64.5
	5	2868	291	198	525	67.6
1200	1	1739	353	319	290	62.6
	2	2154	363	311	365	63.5
	3	2521	357	285	446	65.6
	4	2767	352	265	525	66.7
	5	3129	346	236	681	69.9
1300	1	1884	414	374	369	64.7
	2	2334	426	364	464	65.7
	3	2731	418	334	567	67.7
	4	2997	413	311	668	68.8
	5	3389	406	276	866	72.0
1400	1	2029	480	434	460	66.6
	2	2513	494	423	579	67.5
	3	2941	485	388	708	69.6
	4	3228	479	361	834	70.8
	5	3650	471	321	1082	73.8

外型及安装尺寸 Overall Size and Erection Size

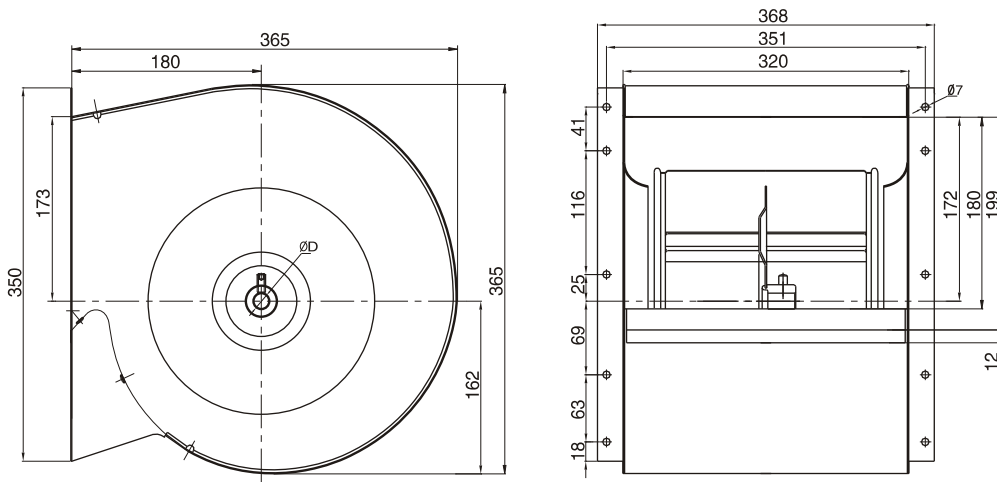

ΦD Φ12.7 Φ15

SYP250/250J-1

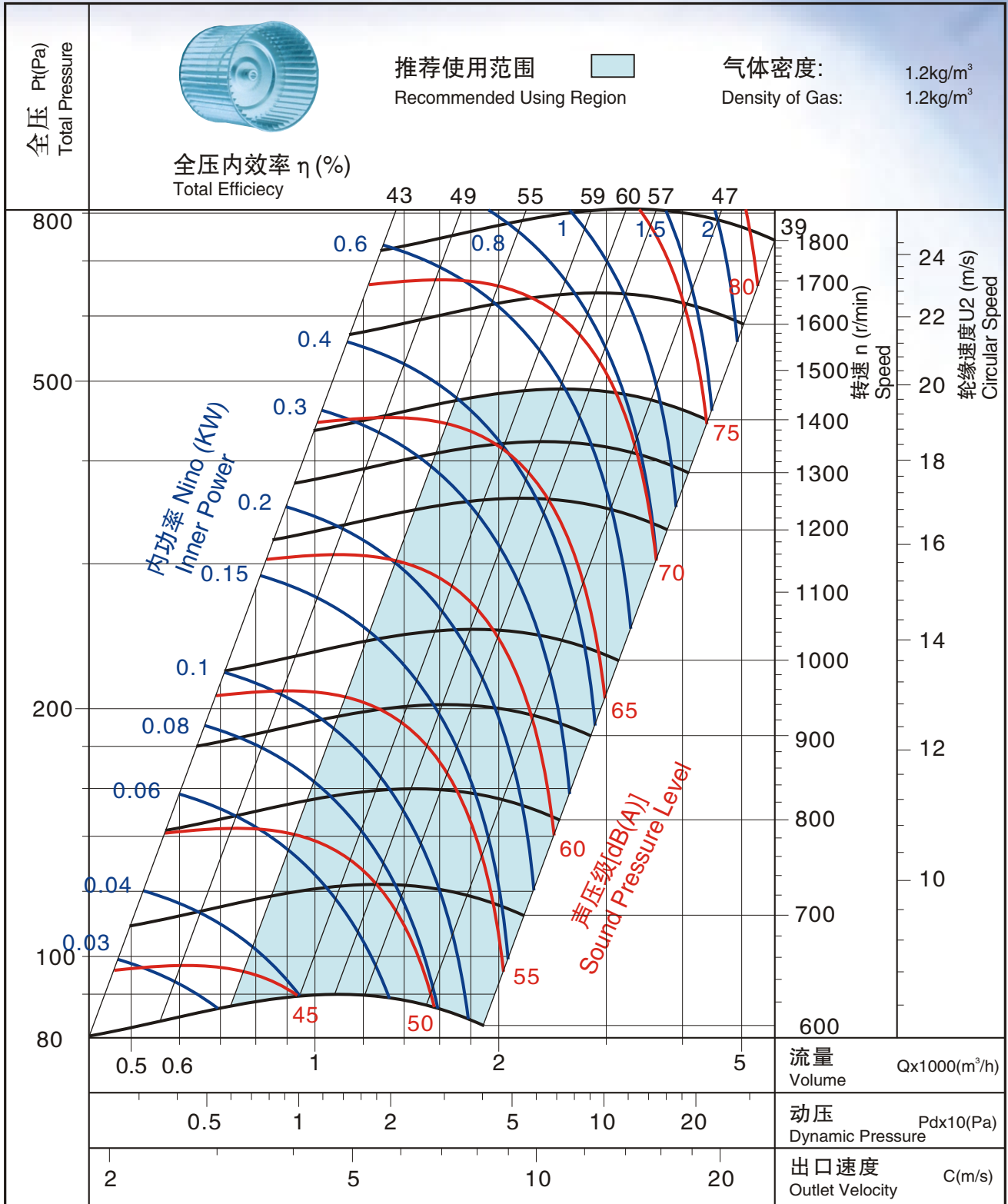

本公司开发生产的冷凝水盘是中央空调风机盘管理想的配套产品,盘体采用优质冷轧钢板(或不锈钢板)整体引伸、双面喷塑,选用优质的保温材料和粘合剂整体粘贴制成,保温材料与盘体结合紧密,具有外观精美、防锈蚀、防凝露、阻燃性强等特点,工艺国内领先,产品规格齐全,先后为100多家空调生产企业配套,目前国内市场占有率在45%以上。

冷凝水盘按盘体内壁宽度不同可分为200、230、242、252、330等系列,规格以盘体内壁的宽度及长度尺寸命名,产品可按顾客所需的长度尺寸、安装要求及指定材料生产。

The condensate water plate developed and manufactured by our company is the matching product of fan coil. The plate body is made of high quality cold-rolled sheet by way of integral cupping, both its sides are sprayed with plastic and lined with high quality heat insulating material and imported adhesive by way of integral adhering and pressing. The heat insulating material and the plate body are tightly bound, thus resulting in the features of fine outward appearance, high anti-corrosion, anti-condensation and high fire reluctance. With the advance technology the condensate plate is an ideal matching product for various fan coils and has been provided for more than 100 air-conditioning equipment companies home and abroad and has over 45% share of the domestic market.

According to the width of inner wall of the plate body, the condensate plate can be divided into series of 200, 230, 242, 252 and 330. The length and width of the inner wall of the plate body is named after the specification of the condensate plate. The company can manufacture the condensate plate according to the requirements of the customers, including length, installation requirement and specified materials.

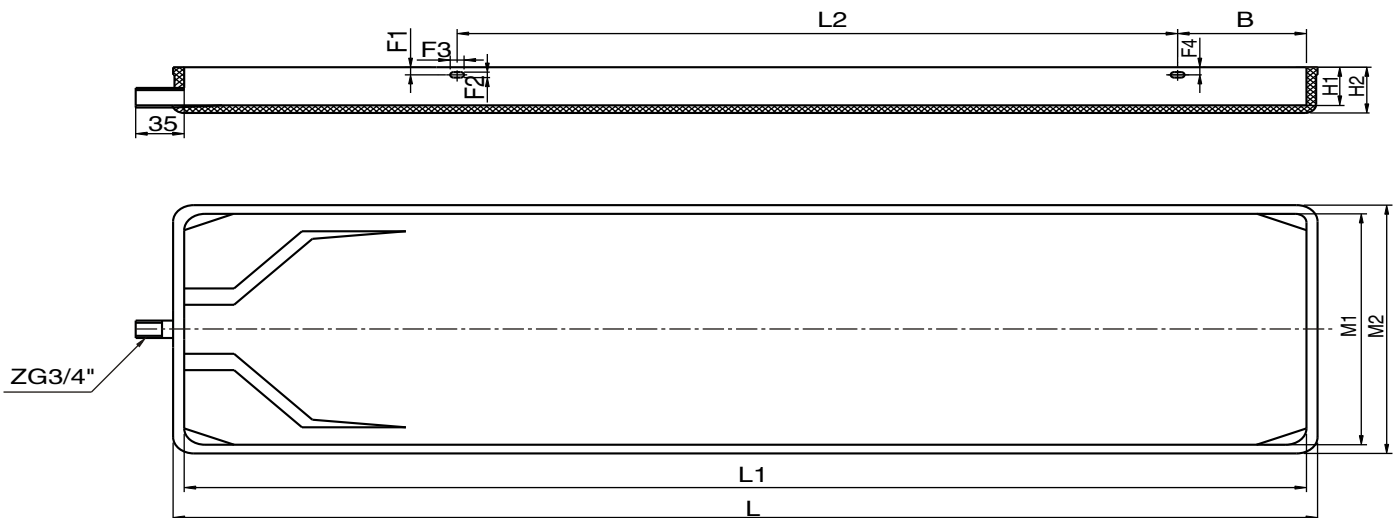
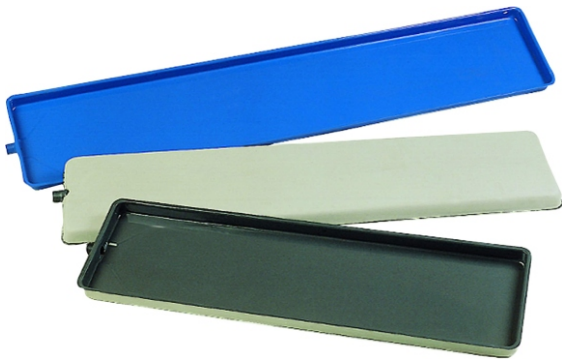

冷凝水盘规格及安装尺寸参考表

Condensate plate table of specifications and installation dimension

	规格	L	L1	L2	B	F1	F2	F3	F4	H1	H2	M1	M2
200 系 列	200-740	756	740	/	/	/	/	/	/	28	35	200	212
	200-840	856	840	/	/	/	/	/	/	28	35	200	212
	200-1040	1056	1040	/	/	/	/	/	/	28	35	200	212
	200-1230	1246	1230	/	/	/	/	/	/	28	35	200	212
	200-1540	1556	1540	/	/	/	/	/	/	28	35	200	212
	200-1840	1856	1840	/	/	/	/	/	/	28	35	200	212
230 系 列	230-740	760	740	430	30	6.5	5	10	9.5	31	38	230	242
	230-840	860	840	510	30	6.5	5	10	9.5	31	38	230	242
	230-930	950	930	620	30	6.5	5	10	9.5	31	38	230	242
	230-1040	1060	1040	700	30	6.5	5	10	9.5	31	38	230	242
	230-1130	1150	1130	820	30	6.5	5	10	9.5	31	38	230	242
	230-1230	1250	1230	920	30	6.5	5	10	9.5	31	38	230	242
	230-1270	1290	1270	900	30	6.5	5	10	9.5	31	38	230	242
	230-1410	1430	1410	1100	30	6.5	5	10	9.5	31	38	230	242
	230-1490	1510	1490	900	30	6.5	5	10	9.5	31	38	230	242
	230-1650	1670	1650	1340	30	6.5	5	10	9.5	31	38	230	242
	230-1790	1810	1790	1480	30	6.5	5	10	9.5	31	38	230	242
230-1900	1920	1900	1560	30	6.5	5	10	9.5	31	38	230	242	
242 系 列	242-710	730	710	520	25	8	5	10	8.5	37	44	242	254
	242-810	830	810	620	25	8	5	10	8.5	37	44	242	254
	242-910	930	910	720	25	8	5	10	8.5	37	44	242	254
	242-1110	1130	1110	920	25	8	5	10	8.5	37	44	242	254
	242-1210	1230	1210	1020	25	8	5	10	8.5	37	44	242	254
	242-1540	1560	1540	1320	25	8	5	10	8.5	37	44	242	254
	242-1920	1940	1920	1720	25	8	5	10	8.5	37	44	242	254
252 系 列	252-797	815	797	510	48.5	5	5	10	8.5	31	38	252	264
	252-1047	1065	1047	760	48.5	5	5	10	8.5	31	38	252	264
	252-1182	1200	1182	895	48.5	5	5	10	8.5	31	38	252	264
	252-1467	1485	1467	1180	48.5	5	5	10	8.5	31	38	252	264
	252-1637	1655	1637	1350	48.5	5	5	10	8.5	31	38	252	264
	252-1887	1905	1887	1600	48.5	5	5	10	8.5	31	38	252	264
	252-2067	2085	2067	1780	48.5	5	5	10	8.5	31	38	252	264
330 系 列	330-665	679	665	506	47	5	5	10	8.5	28	35	330	342
	330-915	929	915	756	47	5	5	10	8.5	28	35	330	342
	330-1050	1064	1050	891	47	5	5	10	8.5	28	35	330	342
	330-1335	1349	1335	1176	47	5	5	10	8.5	28	35	330	342
	330-1505	1519	1505	1346	47	5	5	10	8.5	28	35	330	342
	330-1755	1769	1755	1596	47	5	5	10	8.5	28	35	330	342

样本中所述的产品特性,如尺寸、性能参数等,本公司保留更改的权利,恕不另行通知,如有不明之处,请来电询问。

The datas such as performance, dimensions and etc.in this catalogue is subject to change without notice, Please contact with the manufacturer for further information.



® 浙江亿利达风机有限公司

ZHEJIANG YILIDA VENTILATOR CO.,LTD.

地址：台州市路桥区横街 ADD: Hengjie, Luqiao Distric, Taizhou, Zhengjiang, China 邮编P.C:318056

电话总机TEL: 0086-576-2652888 销售热线Marketing Hotline:0086-576-2565000 2656611 2656612 2653728(外销international trade)

传真FAX:0086-576-2655758 网址 (URL) : <http://www.yilida.com> 电子信箱 (E-mail):info@yilida.com

国内办事处 (OFFICES) : 北京 广州 深圳 江苏 福建 重庆 Beijing Shanghai Guangzhuo Shenzhen Jiangsu Fujan and Chongqing